

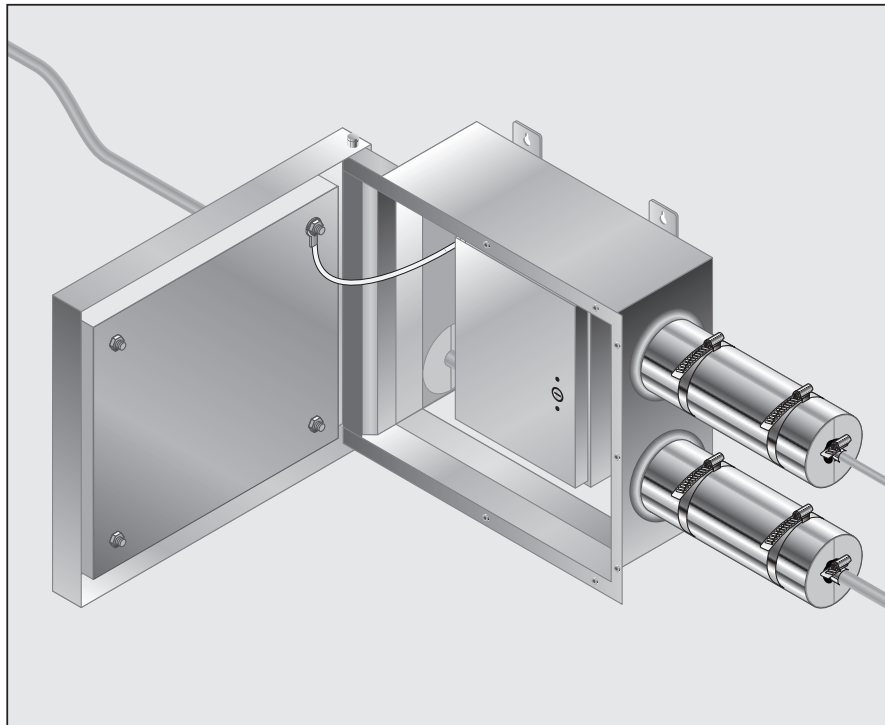

PYROTENAX

Fire-Rated Three-Way Splice

Instructions for Making a Fire-Rated Three-Way Splice



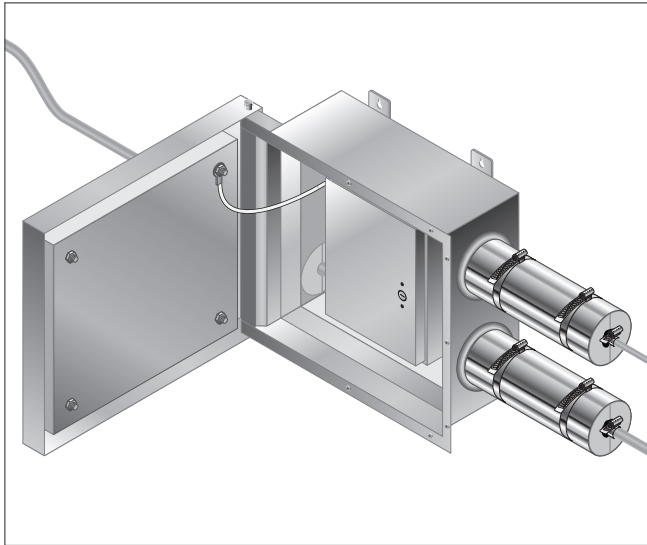

DESCRIPTION

This kit is used to make a three-way fire-rated field splice for nVent PYROTENAX 1850 Mineral Insulated cables. The process includes splicing the cables together inside the heat insulated enclosure and adding the collars for additional heat protection.

For compliance with NEC (NFPA 70, 2014 edition) article 728.5F, this kit must be installed using System 1850 cables if the intent is to create a 1-hour fire-rated circuit.

The Components supplied with this splice kit must be used to complete the splice. Substituting other materials or components will void the 1-hour fire rating and approvals.

For technical support contact your nVent representative or call (800) 545-6258 for assistance.

TOOLS REQUIRED

- Open ended torque wrench for cable compression fitting (See Table 1 for size chart)
- Wrench for cable compression fitting (See Table 1 for size chart)
- Multimeter or continuity tester
- 500 Vdc megohmmeter
- Safety goggles and gloves
- Caulking gun
- Flat head screwdriver
- 3/16 in diameter masonry drill bit (for 1/4 in concrete screws)
- Drill
- Hex driver (for drill) to install masonry screws
- Wrench for inner box bonding wire: 7/16 in
- Loctite® 567™ instant thread sealant

APPROVALS

System 1850 Cables:



Terminations for System 1850 Cables:



Electrical Enclosure:



Completed Splice:

- Splice is part of the Electrical Circuit Integrity System (FHIT) System No. 1850 in the UL Fire Resistance Directory when used with UL Classified System No. 1850 Cable (tested with hose stream)
- Splice is part of the Electrical Circuit Integrity System Certified for Canada (FHIT7) System No. 1850 in the ULC Fire Resistance Directory when used with ULC Classified System No. 1850 Cable (tested with hose stream)



UL Classified, 1-hour fire-resistive cable, tested to UL 2196



ULC Listed, 1-hour fire-resistant cable, tested to ULC-S139

Note: If the enclosure is the last in the series, refer to this installation instruction for installing and insulating the main and branch cable. Next, refer to installation instruction H60459 (Fire-Rated Three-Way Splice End Enclosure Sealing kit) to plug, insulate and seal the third entry into the enclosure since the final enclosure in the series only has 2 cable entries used.

WARNING:

This component is an electrical device that must be installed correctly to ensure proper operation and to prevent shock or fire. Read these important warnings carefully and follow all installation instructions.

- Store all splice kit components indoors in a clean, dry area.

CAUTION:

HEALTH HAZARD. Consult your nVent representative or call (800) 545-6258 for MSDS safety information regarding the calcium silicate box insulation and collars.

KIT CONTENTS: ALL TYPES

Item	Qty	Description
A	1	Enclosure
B	4	Concrete screws for enclosure mounting
C	1	3M™ fire barrier sealant
D	1	Collar for branch line
E	2	Collars for main power line
F	6	Hose clamps
G	3	Shields for collars

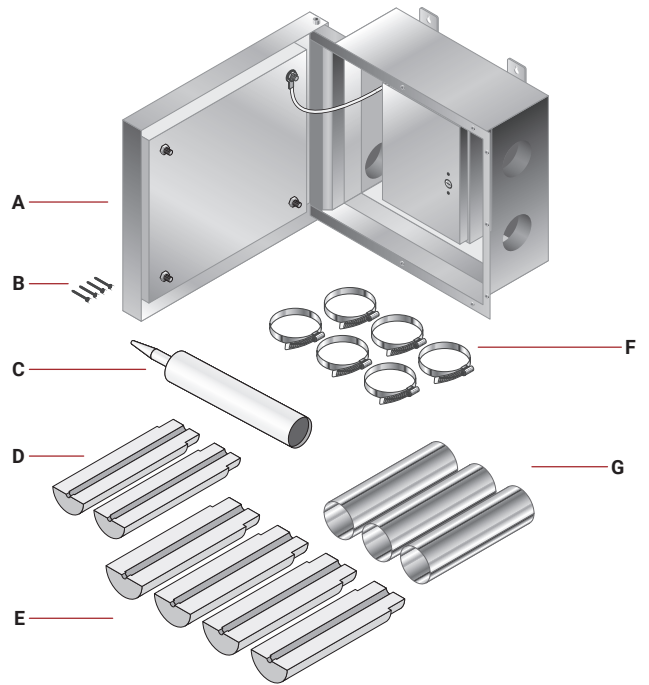

**KIT CONTENTS: PRE-TERMINATED CABLES
(OR FIELD TERMINATED CABLES*)**

Item	Qty	Description
A	1	Pre-terminated main power line cable (assumes first line is already installed)
B	1	Pre-terminated branch line cable

* See Fire-Rated Three-Way Splice Field Termination Instructions H60235 for details.

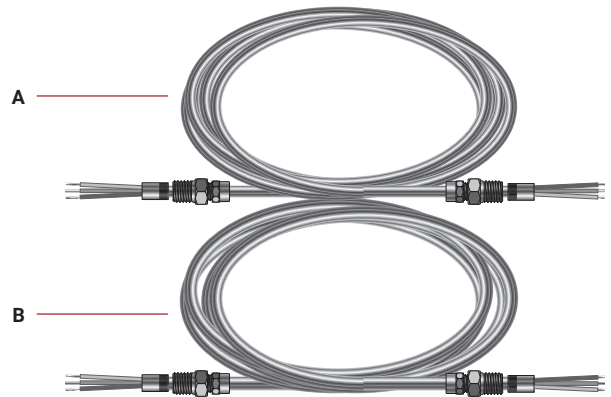

- Using a 500-Vdc megohmmeter, check the insulation resistance (IR) of the cable to ensure it is free of grounds and shorts. Check IR between conductor(s) and sheath, and between each pair of conductors. See Appendix A for detailed test procedure and IR test criteria.
- Ensure that both ends of the MI cable are straight for at least 28 in (71 cm) length from the back of the pot. If the cable has a polymer jacket, also remove 22 in (56 cm) length of the jacket from each end, starting at the back of the pots.

Note: (Jacketed Cables Only): Once the fire-rated splice assembly is complete, approximately 4 in (10 cm) of bare cable will be exposed to the environment on either side of the splice. Consult your nVent representative or call (800) 545-6258 for means of protecting the exposed cable.

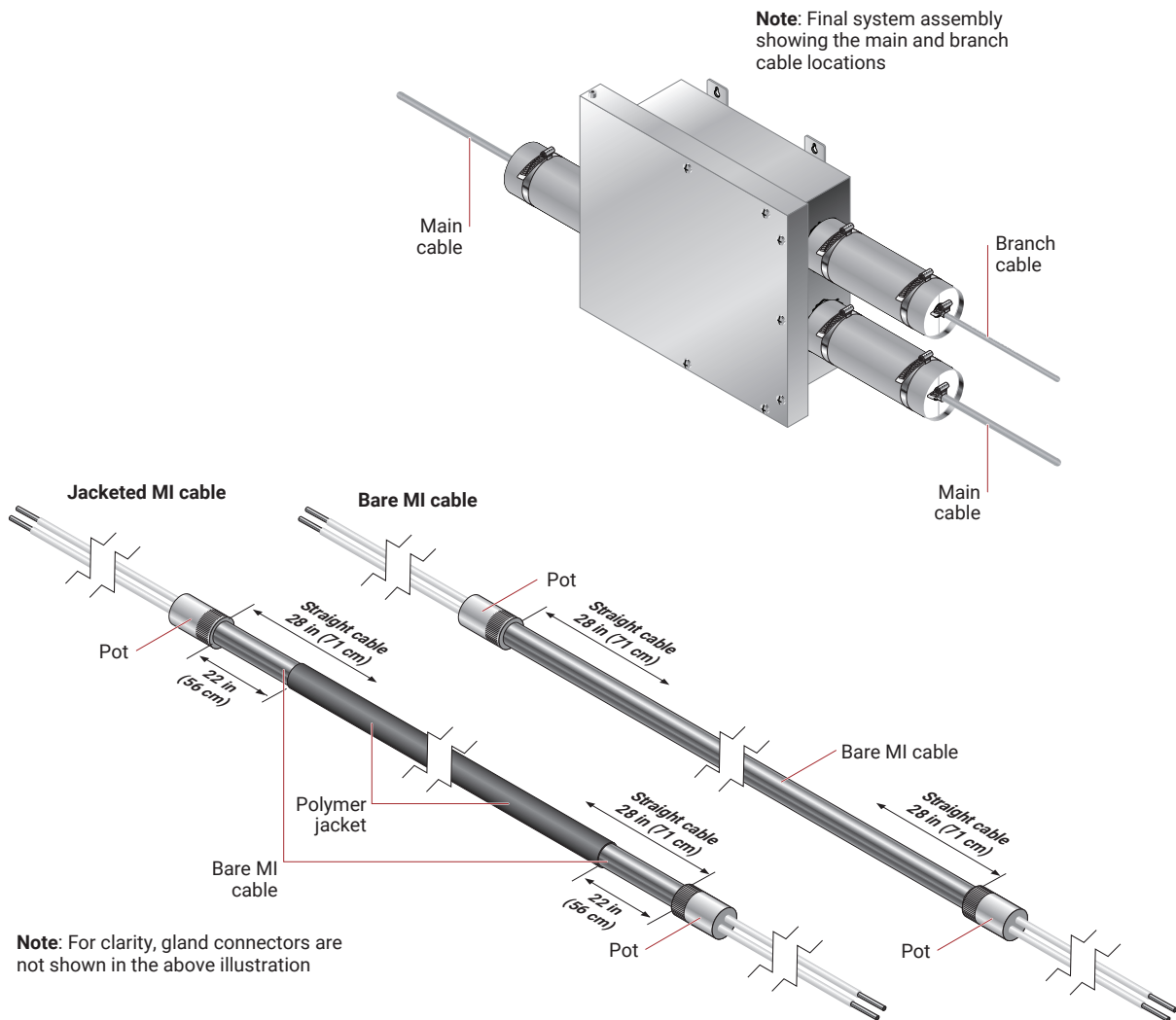

- Open the outer enclosure and ensure the bonding wire is not attached to the door. Remove if necessary using a 7/16 in wrench.
- With the outer enclosure door half opened as shown on the illustration, remove the door by pulling the removable hinge pins. Rotate the pin to lock it in open position.

Important: Handle door with care, making sure not to drop it as the calcium silicate insulation may crack or break.

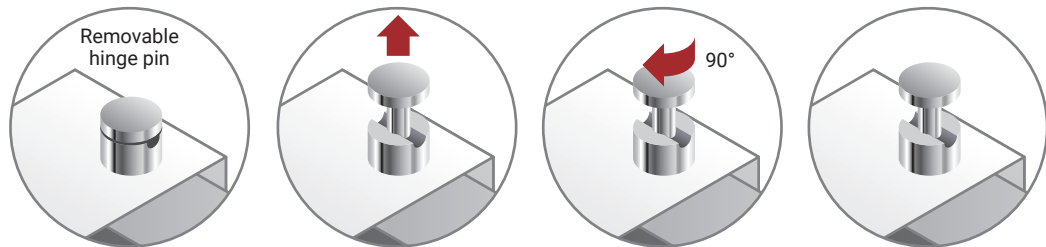
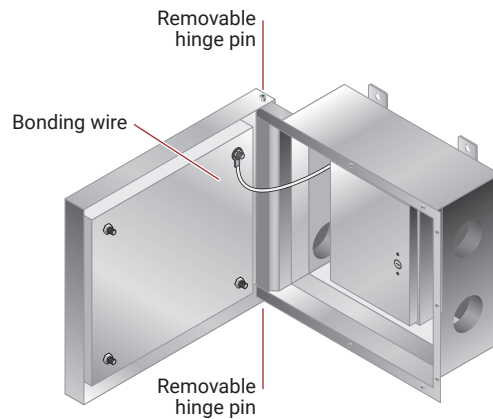

- Locate enclosure position near the terminated end of the existing cable such that this cable has enough slack to enter the enclosure. There should be enough cable length for the back of the pot to sit approximately 1/4 in (6 mm) past the inner enclosure threaded entry.

Note: If it is the initial enclosure, locate its position so as to extend the cable from the enclosure into the fireproof room.

Note: Do not insert the cable /termination inside the box yet as the box has to be secured first. The illustration is a reference only to show how the installed cable should be sitting inside the box.

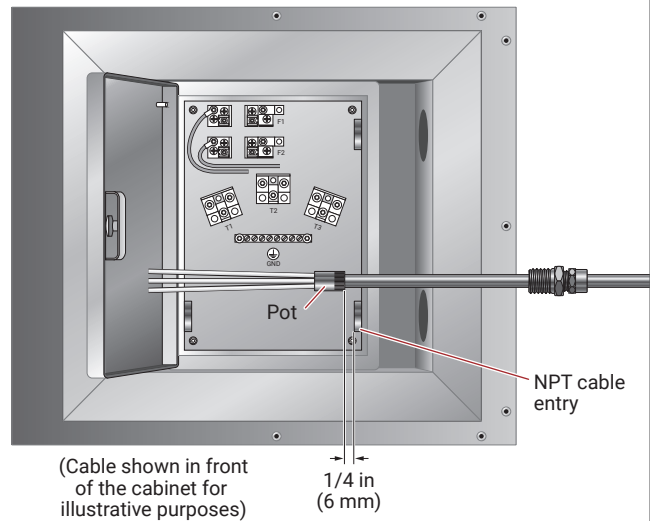

3

- Mark 2 points on the 1-hour fire-rated structure (concrete or masonry surface) for the upper support screws on the enclosure, 10 in (25 cm) apart. Drill the top 2 holes using the appropriate masonry drill bit for the concrete screws used.
- Install the concrete screws, leaving a 3/4 in (19 mm) space between the head and the wall. ❶
- Hang the enclosure onto the newly installed concrete screws.
- With the enclosure in place, drill the lower 2 holes and install the other 2 concrete screws. ❷
- Once the bottom of the enclosure is secured, finish tightening the top two concrete screws.

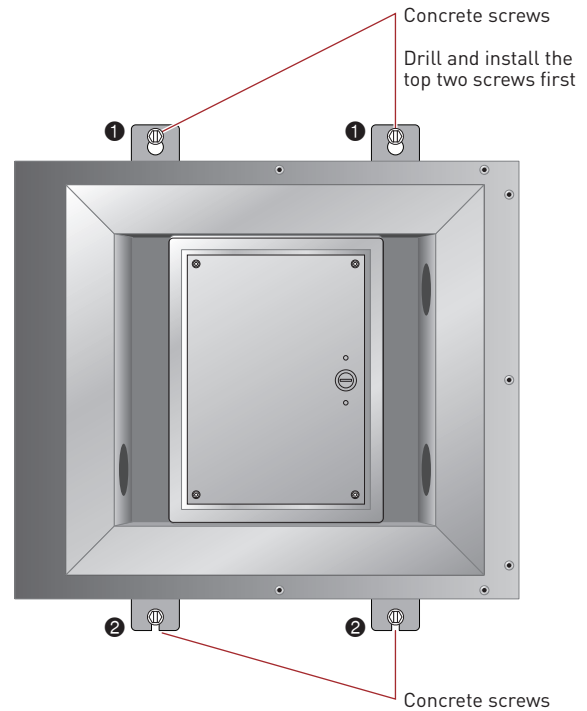

4

Note: Keep a minimum of 28 in (71 cm) of cable straight when making the entry into the enclosure.

- Slide initial main power cable through the outer enclosure, into the inner enclosure so that the back of the pot sits approximately 1/4 in (6 mm) beyond the end of the threaded entry.
- Bend the MI cable a minimum of 20 in (50 cm) away from the box wall to the wall structure, and secure it using approved fasteners according to Cable Installation Manual H57864.

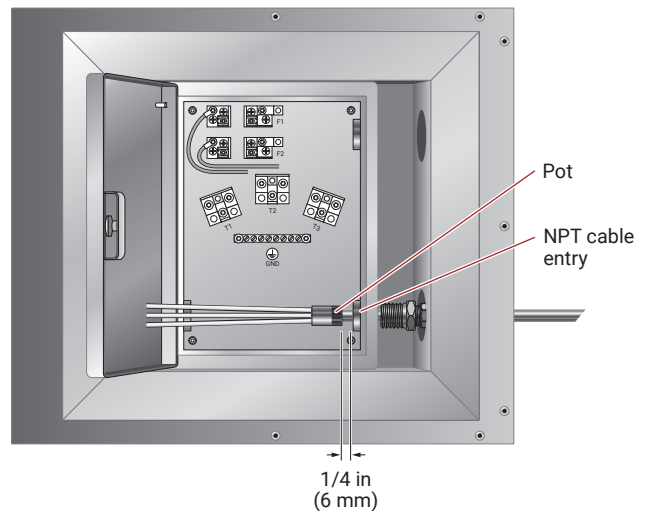
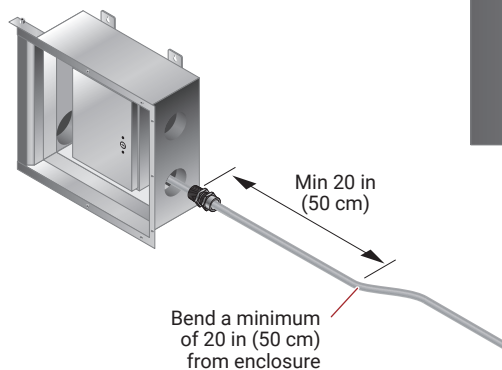

5

- Loosen the gland connector back nut until only one or two threads hold it to the gland body.
- Apply a 360° bead of Loctite 567 thread sealant to the leading NPT thread of the gland body, leaving the first 2 threads free. Thread the gland into the inner box threaded entry (hand tight).

Note: When threading the gland body into the box threaded entry, keep back nut from tightening.

WARNING: Do not apply thread sealant to the gland back nut threads. Only apply to the gland NPT threads.

- Repeat Steps 4 and 5 for the other main power cable.

Note: If the enclosure is the last in the series, do not attach a second cable. Refer to Installation Instruction H60459 (Fire-Rated Three-Way Splice End Enclosure Sealing kit) to seal the unused enclosure entry.

Table 1: Gland Hex sizes (back nut & gland body)

Gland NPT thread size	Back nut hex size (torque wrench – 25 ft-lbs)		Gland body hex size (standard wrench)	
3/4 in	15/16 in	(24 mm)	1-1/16 in	(27 mm)
1 in	1-1/16 in	(27 mm)	1-7/16 in	(36 mm)
1-1/4 in	1-7/16 in	(34 mm)	1-13/16 in	(46 mm)

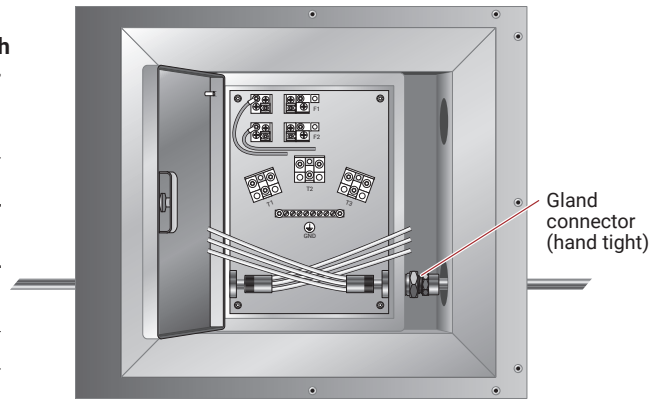
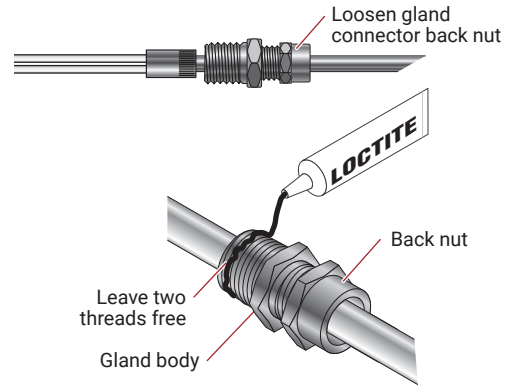

6

- Taking the conductors from the rear most cable (the cable entering on the right side), bend the conductors into the desired position for each terminal.
- Trim the conductors as necessary and strip back the white insulation to expose approximately 1/2 in (13 mm) of bare conductor.
- Feed the exposed conductors into the terminals and tighten as per Table 2 on page 8.
- Repeat for the other main power cable.

Note: See Appendix B for standard configuration wiring diagrams. For non standard configurations, contact nVent technical support at (800) 545-6258 for assistance.

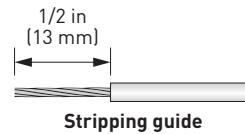
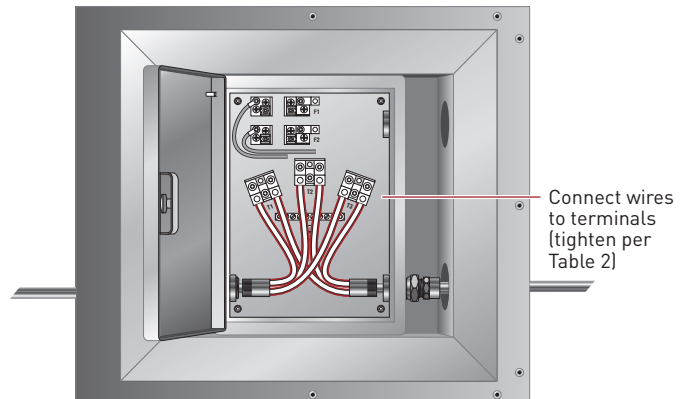

- Connect the ground wire (if utilized) and all unused conductors to the grounding terminal bar and tighten as per Table 2 below.

Note: See Appendix B for standard configuration wiring diagrams. For non standard configurations, contact nVent technical support at (800) 545-6258 for assistance.

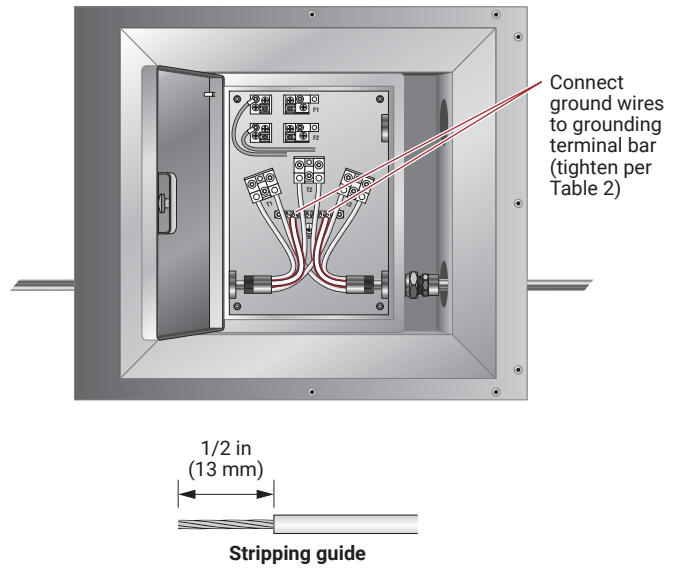
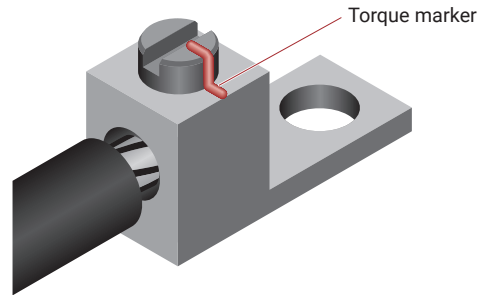

Table 2: Torque Requirements

Field Wiring			
Torque Location	No. of Points	Conductor Size	Tightening Torque (in-lbs)
Input/Output Terminal Connectors (Main & Branch)	6–18	14 AWG – 12 AWG	35
		10 AWG – 8 AWG	40
		6 AWG	45
		4 AWG – 1 AWG	50
Equipment Ground Terminals	Up to 8	14 AWG – 10 AWG	35
		8 AWG	40
		6 AWG – 4 AWG	45



Note: Conductors sized to 90°C ampacity table.

Note: After torquing, mark connector with torque marker or permanent marker.

WARNING: For continued protection against risk of equipment damage and fire and to maintain fire-rated certification, replace only with fuse of the specified type, current and voltage rating as listed below:

Table 3: Approved Fuses List

Fuse Type	Rating	Minimum Branch Gauge	Fuse Type	Rating	Minimum Branch Gauge
ATMR1/10	0.1 A	14 AWG	ATMR3-1/2	3.5 A	14 AWG
ATMR1/8	0.125 A	14 AWG	ATMR4	4.0 A	14 AWG
ATMR2/10	0.2 A	14 AWG	ATMR5	5.0 A	14 AWG
ATMR1/4	0.25 A	14 AWG	ATMR6	6.0 A	14 AWG
ATMR3/10	0.3 A	14 AWG	ATMR7	7.0 A	14 AWG
ATMR1/2	0.5 A	14 AWG	ATMR8	8.0 A	14 AWG
ATMR3/4	0.75 A	14 AWG	ATMR9	9.0 A	14 AWG
ATMR1	1.0 A	14 AWG	ATMR10	10 A	14 AWG
ATMR1-1/4	1.25 A	14 AWG	ATMR12	12 A	14 AWG
ATMR1-1/2	1.5 A	14 AWG	ATMR15	15 A	14 AWG
ATMR2	2.0 A	14 AWG	ATMR20	20 A	12 AWG
ATMR2-1/2	2.5 A	14 AWG	ATMR25	25 A	10 AWG
ATMR3	3.0 A	14 AWG	ATMR30	30 A	10 AWG

8

Note: Keep a minimum of 28 in (71 cm) of cable straight when making the entry into the enclosure.

- Slide the branch cable through the outer enclosure, into the inner enclosure so that the back of the pot is flush with the end of the threaded entry.
- Bend the MI cable a minimum of 20 in (50 cm) away from the box wall to the wall structure. Do not secure cable to the wall at this time.

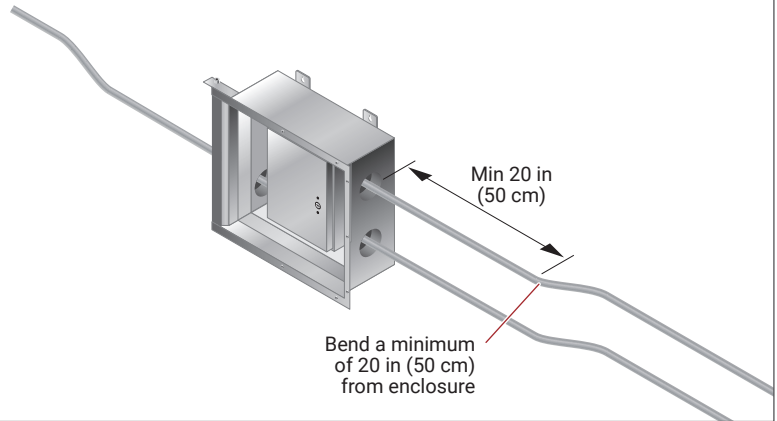
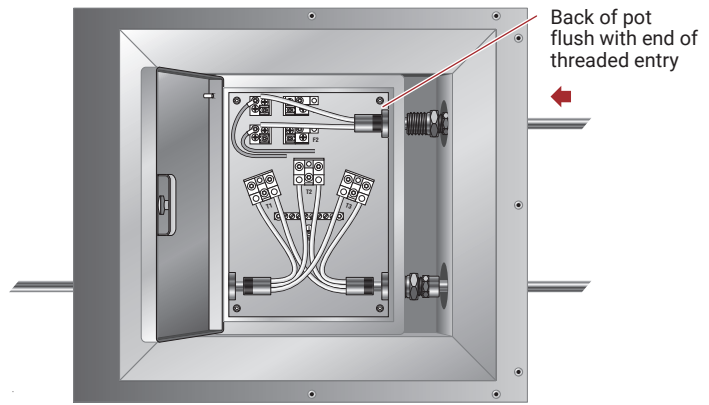

9

- If connecting a 3-conductor branch circuit cable, select the conductors going into the fuse terminals, typically the two wires located in front (the furthest away from the mounting pan).
- Trim the two conductors going into the fuse terminals so that they come about 1/2 in (13 mm) past the fuse terminal entries - length should be about 2.5 in (6.5 cm) from the face of the pot- leaving the ground wire long if a 3-conductor cable is being connected. Strip back the white insulation to expose approximately 1/2 in (13 mm) of bare conductor.

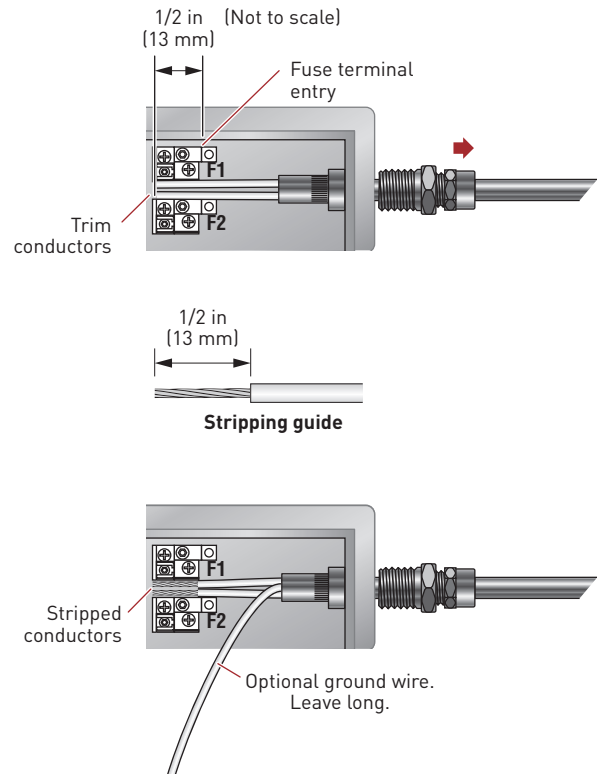

- 1 Loosen the gland connector back nut until only one or two threads hold it to the gland body.

- 2 Apply a 360° bead of Loctite 567 thread sealant to the leading NPT thread of the gland body, leaving the first 2 threads free. Thread the gland into the inner box threaded entry (hand tight).

Note: When threading the gland body into the box threaded entry, keep back nut from tightening.

WARNING: Do not apply thread sealant to the gland back nut threads. Only apply to the gland NPT threads.

- 3 Back up the cable enough to be able to insert the newly trimmed conductors into the fuse terminals.

- 4 Push cable while inserting wires into terminals.
- 5 Connect the conductors into fuse terminals and tighten the terminals as per Table 2 on page 8.

- 6 Connect the ground wire (if utilized) to the grounding terminal bar and tighten as per Table 2 on page 8.

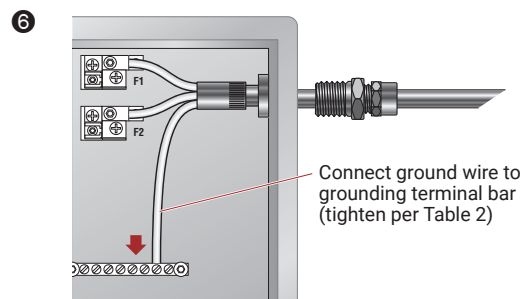
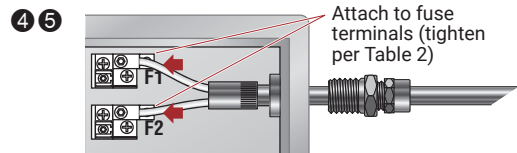
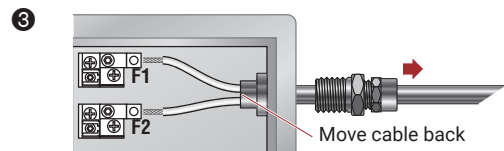
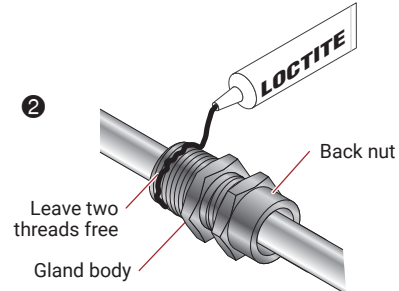
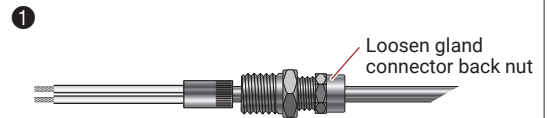

11

- Trim the supplied 10 AWG branch fuse wire(s) as required and connect to the desired main terminals. Tighten to 35 in-lbs (per Table 2 on page 8).

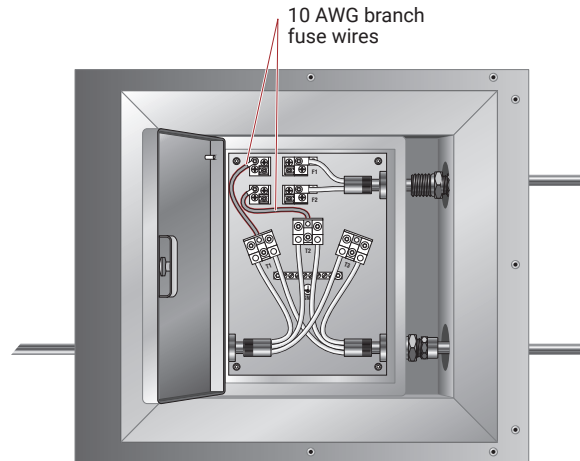

12

- Wrench tighten all three gland connectors to the inner enclosure.
- Finally, using a torque wrench, tighten all three gland back nuts per the recommended torque on the supplied torque tag (25 ft-lbs).

 **Note:** Both the gland body and the back nut must be sufficiently torqued to achieve the desired sealing requirement and keep the enclosure NEMA 4X rating.

 **Note:** It is also critical to maintain the grounding continuity between the MI cable sheath and the inner enclosure. If in doubt check continuity with a multimeter / ohmmeter. Re-tighten the gland leading thread (gland body) to the inner enclosure as necessary.

- Insert desired fuses if not already done (See Table 3 page 8).
- Close the inner enclosure door.

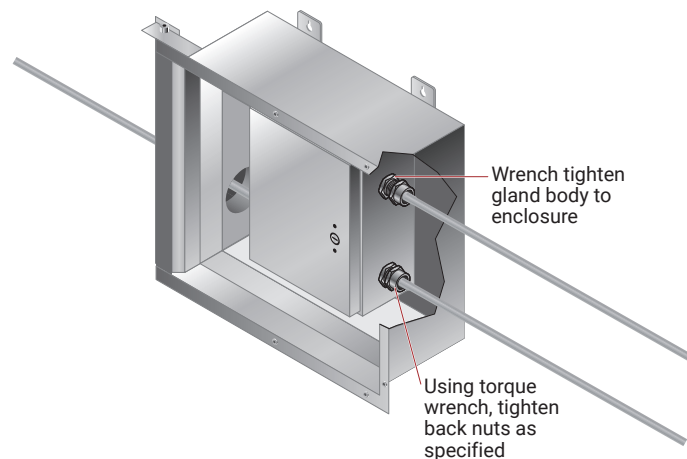

- 1** Apply 1/4 in (6 mm) bead of 3M fire barrier sealant around the first collar half shoulder.

- 1a** Insert collar into the entry until it sits flush with the box (squeezing the fire barrier sealant).

- 2** Repeat for the second collar half.

2a

- 3** Apply a 1/4 in (6 mm) bead of fire barrier sealant around the collar entry where the collar meets the box.

- 4** Using gloves, ensure there is sealant all around by running your finger around the circumference.

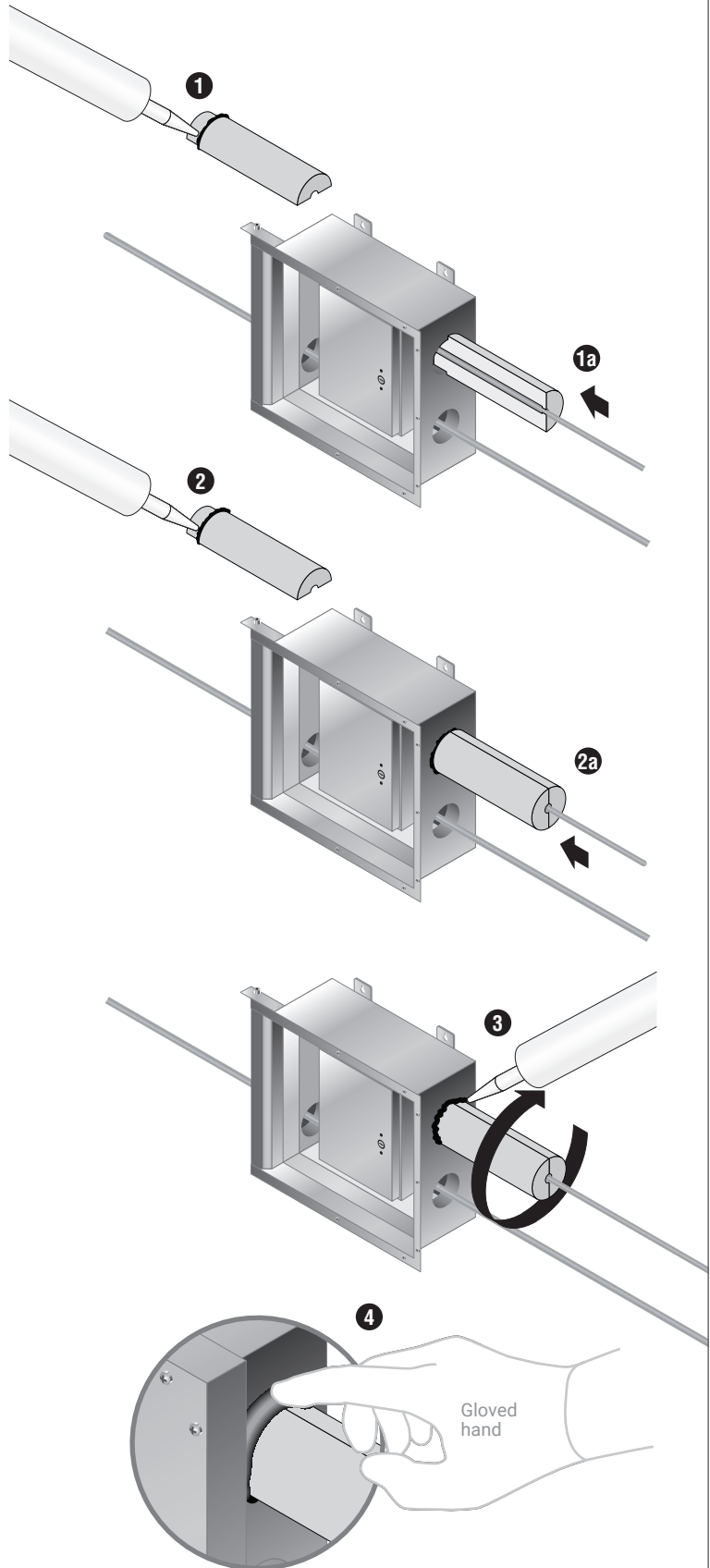

- Wrap supplied metal shield around the installed collar so that it sits against the metal box where the fire barrier sealant has just been applied. Align outside seams of metal to the 3 or 9 o'clock position, pointing downward. This will minimize water entry after installation.

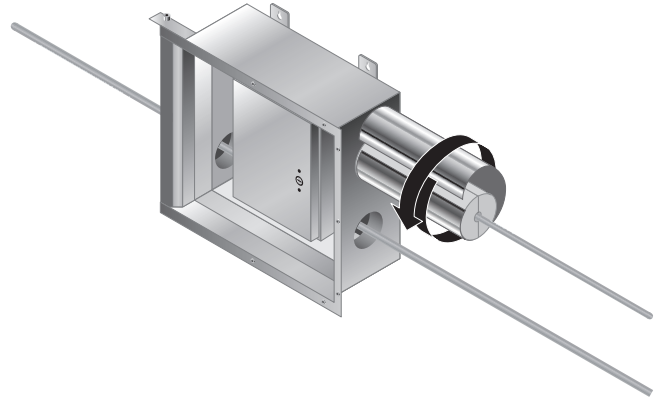

- Pushing the collar toward the box and ensuring it is still flush and resting against the box, tighten the hose clamps so they sit 1 to 2 in (2.5 to 5 cm) away from the box and 1 to 2 in (2.5 to 5 cm) away from end of the collar. Do not tighten completely.

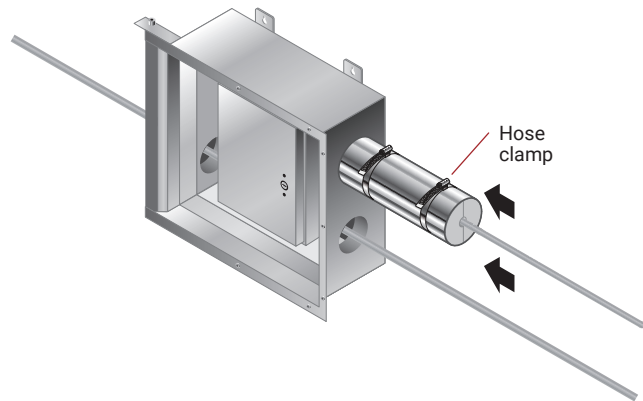

- 1 Apply a 1/2 in (13 mm) bead of fire barrier sealant where the cable enters the collar. Add sealant until there is no gap between the cable and the collar.

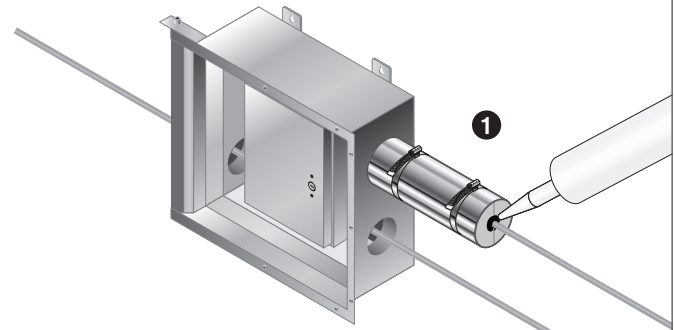

- 2 Pushing the collar toward the box and ensuring it is still flush and resting against the box, install the collar stop clamp (small hose clamp) where the cable enters the collar (i.e. where the sealant was just applied) so that the clamp rests against the collar.

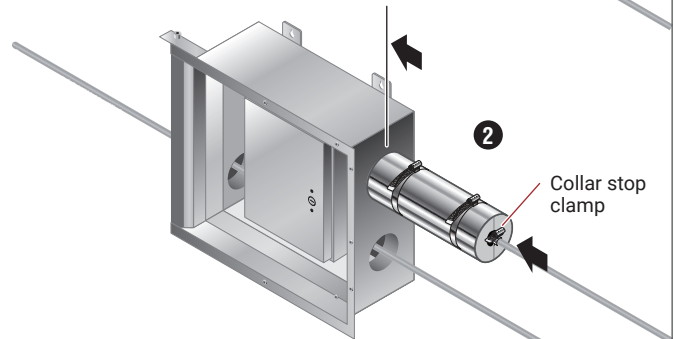

Finish tightening the metal shield.

-  **Note:** Always use a low torque setting if using a drive to tighten the collar stop clamp.

- 3 Apply one last 1/4 in (6 mm) bead of fire barrier sealant around the collar entry where the collar shield meets the box.

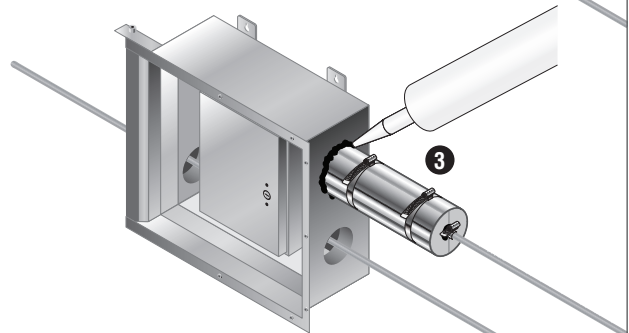

- 4 Using gloves, ensure there is sealant all around by running your finger around the circumference.

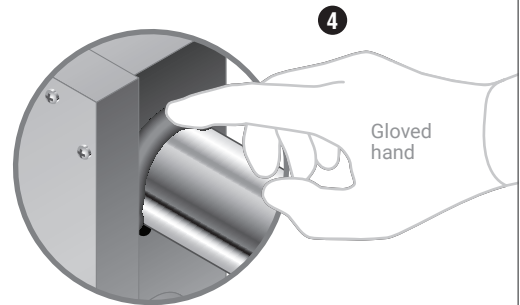

- 5 Repeat Steps 13, 14 and 15 for all remaining cables.

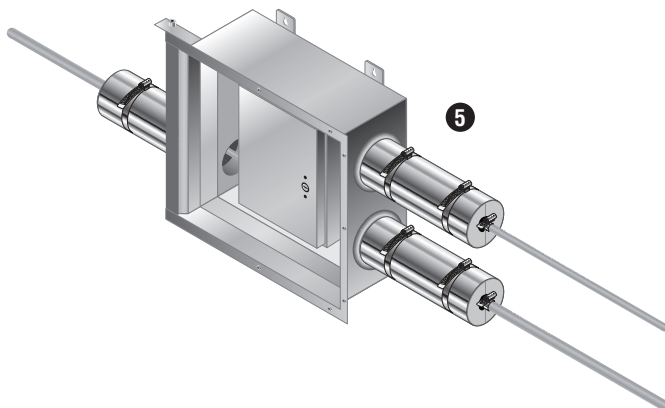

- Re-install outer door onto enclosure, inserting the hinge pins back into their original position. If the pins are locked in the open position, rotate the pin slightly to release.

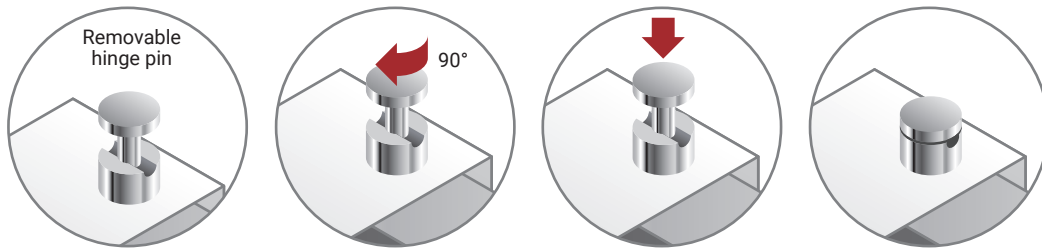

- Re-attach the bonding wire to the outer enclosure door, torquing to 65 in-lbs. Ensure the proper stack-up is observed: door insulation, flat washer, bonding wire ring lug, Belleville washer, hex nut. Ensure bonding wire lug is oriented vertically, with the bonding wire at the 6 o'clock position.

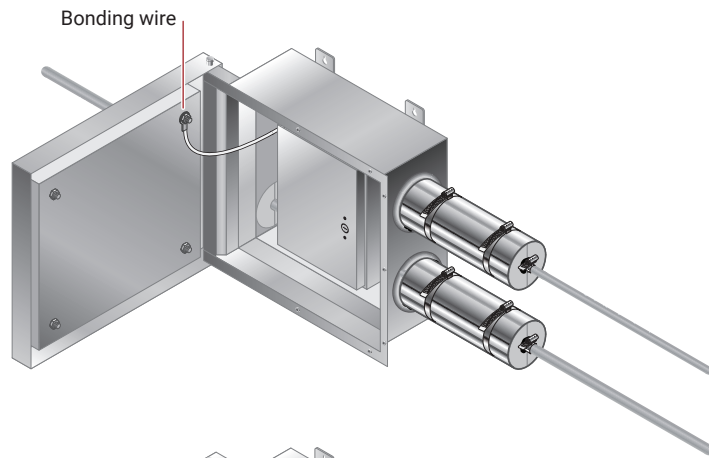

- Close and secure the outer enclosure door by tightening the 7 screws to 10 in-lbs.

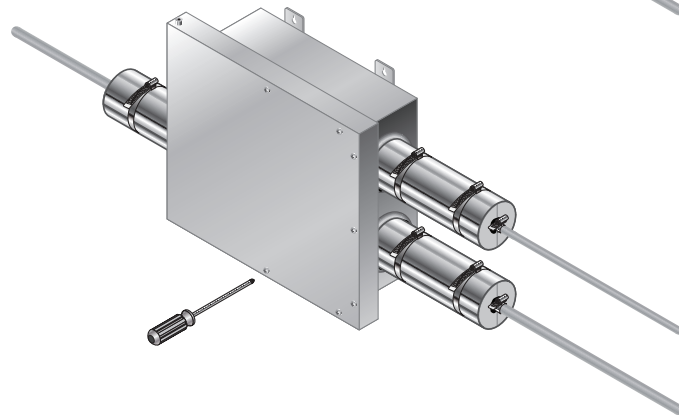

- If not completed in earlier steps, bend the cable a minimum of 8 in (20 cm) past end of collar to the wall structure, and secure using approved fasteners according to Cable Installation Manual H57864.

Note: Do not bend the MI cable too close from the collar as it may damage it.

- Run the main power cable to the next enclosure point, securing it to the fire-rated structure using approved fasteners according to Cable Installation Manual H57864.

Note: (Jacketed cables only): Once the fire-rated splice assembly is complete, approximately 4 in (10 cm) of bare cable will be exposed to the environment on either side of the splice. Consult your nVent representative or call (800) 545-6258 for means of protecting the exposed cable.

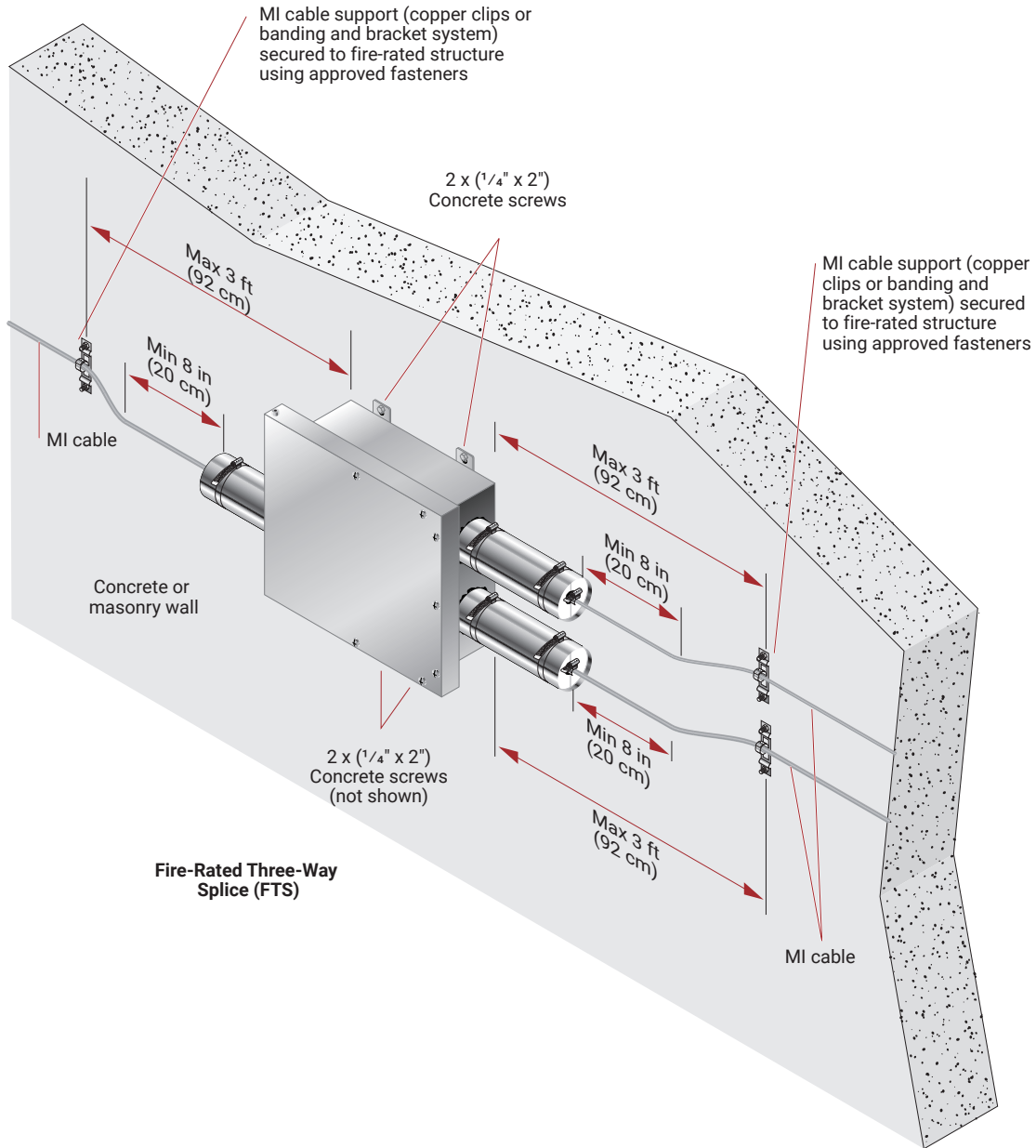

Appendix A: Insulation Resistance (IR) Test

Test Equipment

- 500-Vdc Megohmmeter

IR Testing

- IR testing is conducted using a megohmmeter and tests the integrity of the cable between the conductor and the copper sheath and between conductor pairs.

Test Criteria

- When received:
 - Check cable on reel. Note that ends may need to be prepared to allow insulation resistance (IR) readings to be taken. IR readings must not be less than 200 M Ω under any conditions.
- Terminated cable:
 - In a warm, dry environment, IR readings should be 200 M Ω or higher.
 - In an outdoor environment or indoors in wet or humid conditions, IR readings should all be above 100 M Ω .
 - Similar cables exposed to similar conditions should all have IR readings in the same general range. Where a large difference in readings is encountered, high readings can be accepted; low readings (below 100 M Ω) should be checked as described below.

 **Note:** Under some installation conditions it may not be possible to obtain IR readings above 100 M Ω . If IR readings are between 25 M Ω and 100 M Ω , wait 24 hours and recheck the IR using the same equipment. If the IR reading has not decreased, the termination is good - a constant low IR reading can result from moisture entrained in the cable while making a good seal; this moisture will not increase. If the IR reading has decreased, the cable must be re-terminated - a low IR reading can result from a poorly made seal which will allow continuing moisture ingress, requiring that the termination be redone.

If the IR reading is less than 25 M Ω , the cable must be re-terminated following the “drying out” procedure in Appendix D.

Test Procedure

1. Set megohmmeter test voltage at 0 Vdc or off.
2. Connect the positive (+) (earth) lead to the cable sheath.
3. Connect the negative (-) (line) lead to the conductor.
4. Turn on the megohmmeter and set the voltage to 500 Vdc; apply the voltage for one minute. Meter needle should stop moving. Rapid deflection indicates a short. Note the insulation resistance value. It should correspond to the values shown under Test Criteria.
5. Turn off the megohmmeter.

 **WARNING: Shock Hazard. The MI cable can store a large electrical charge after the insulation resistance test is performed. To prevent personal injury from electrical shock, fully discharge the cable prior to disconnecting the megohmmeter. Many meters will discharge automatically. However, it may be necessary to short the cable leads. Contact your supervisor or the instrument manufacturer to verify the safest practice.**

6. If the megohmmeter does not self-discharge, discharge phase connection to ground with a suitable grounding rod. Disconnect the megohmmeter.

 **Note:** Depending on the type of cable being tested, you will need to repeat the steps in this procedure for each of the conductors present in the MI cable. Also repeat testing for all conductor pair combinations (i.e. connect the leads from the megohmmeter to each conductor pair). If IR readings are low, follow the drying out procedure in Appendix D.

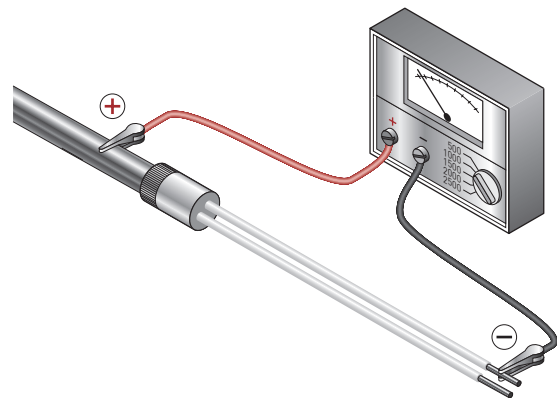

**Two-conductor configuration (main power and branch line)
Single phase power**

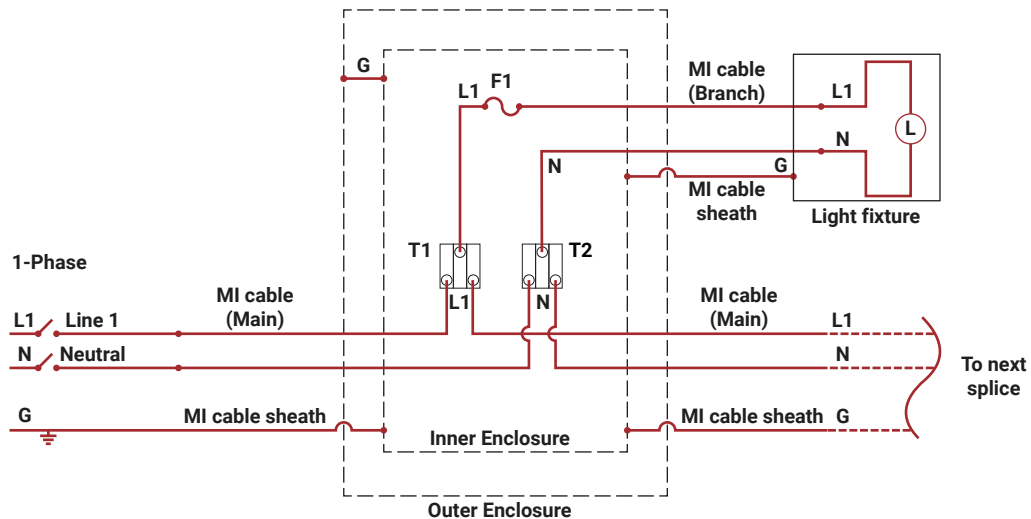

**Two-conductor configuration (main power and branch line)
Single phase power (2 pole)**

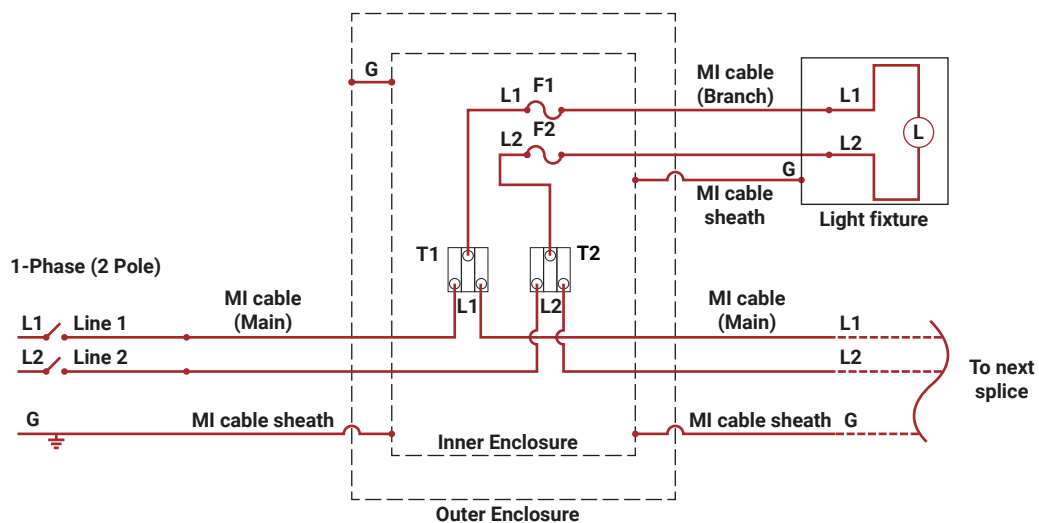

Notes:

- 1 Ground is carried by the MI cable copper sheath.
- 2 Fire-rated enclosure is metal and is bonded via the the MI gland connectors (compression fittings): the brass gland threads into the inner enclosure and compresses onto the MI cable sheath.
- 3 Terminals: T1, T2
- 4 Fuses: F1, (F2) Refer to Page 8 for approved fuses list.

Three-conductor configuration (main power) with two-conductor branch line
Three-phase power supply

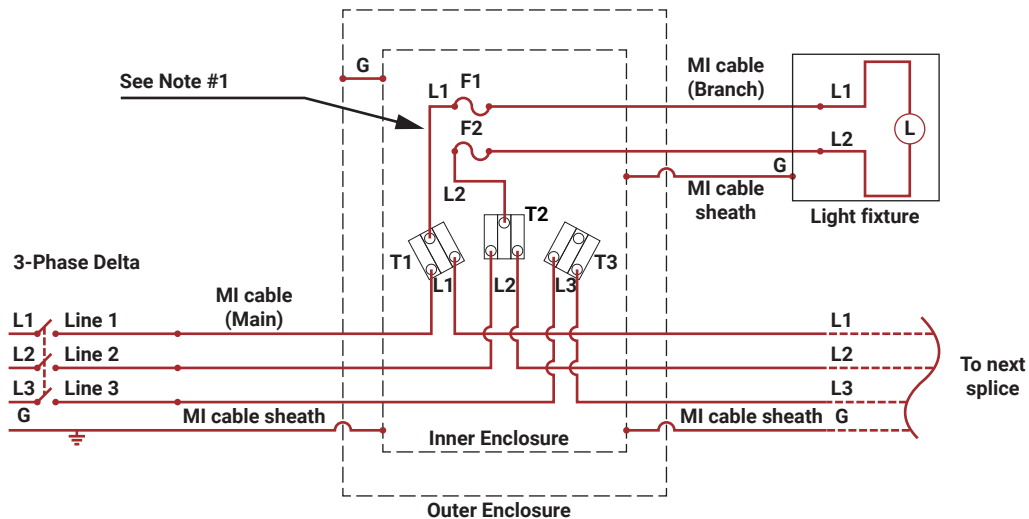

Four-conductor configuration (main power) with two-conductor branch line
Three-phase power supply

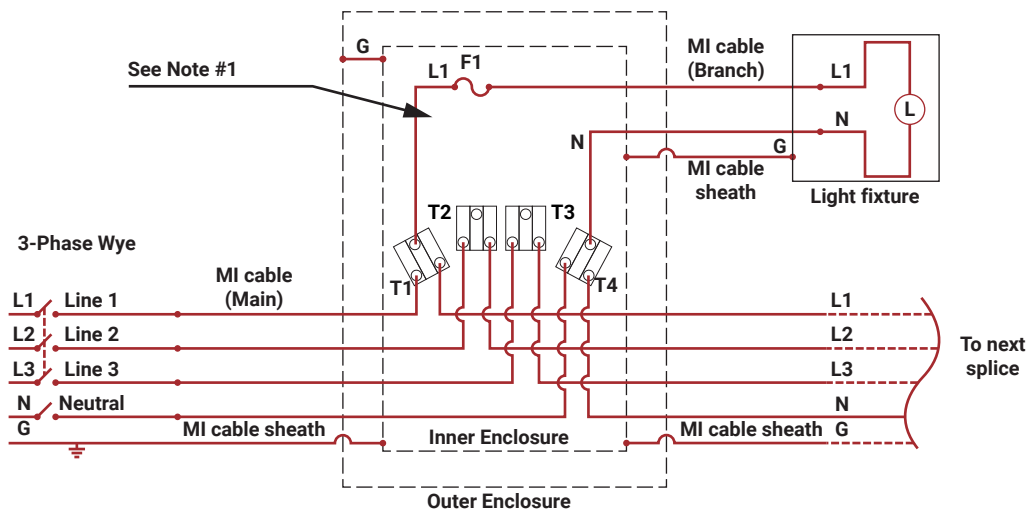

Notes:

- 1 Typical installation showing single phase light fixture powered by Line L1. Wire appropriately for balanced 3-phase distribution.
- 2 Ground is carried by the MI cable copper sheath.
- 3 Fire-rated enclosure is metal and is bonded via the MI cable gland connectors (compression fittings): the brass gland threads into the inner enclosure and compresses onto the MI cable sheath.
- 4 Terminals: T1, T2, T3, (T4).
- 5 Fuses: F1, (F2) Refer to Page 8 for approved fuses list.

NORTH AMERICA

Tel: +1.800.545.6258
Fax: +1.800.527.5703
Tel: +1.650.216.1526
Fax: +1.650.474.7711
thermal.info@nvent.com



nVent.com/PYROTENAX

© 2018 nVent. All nVent marks and logos are owned or licensed by nVent Services GmbH or its affiliates. All other trademarks are the property of their respective owners. nVent reserves the right to change specifications without notice.

Pyrotanax-IM-H60149-FieldInstalledFireRatedTeeSpliceKit-EN-1809