

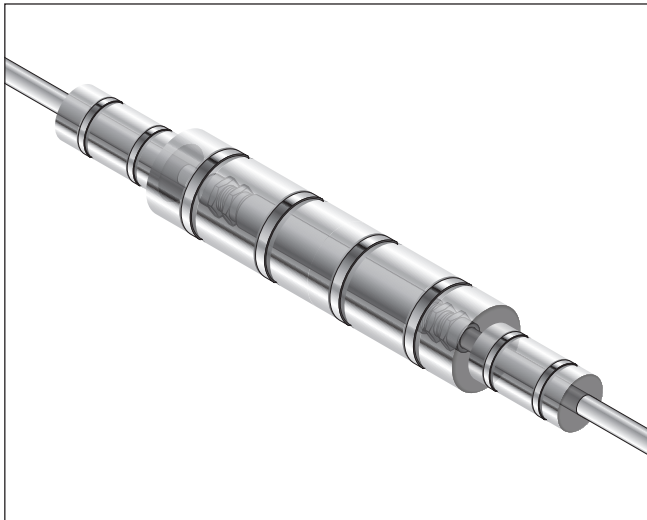

PYROTENAX

Field Installed Fire-Rated Splice Kit

Instructions For Making A Fire-Resistive Field Splice



APPROVALS



Nonhazardous Locations

- Splice is part of the Electrical Circuit Integrity System (FHIT) System No. 1850 in the UL Fire Resistance Directory when used with UL Classified System No. 1850 cable (tested with hose stream)
- Splice is part of the Electrical Circuit Integrity System (FHIT7) System No. 1850 in the ULC Fire Resistance Directory when used with ULC Listed System No. 1850 cable (tested with hose stream)



UL Classified, 2-hour fire-resistive cable, tested to UL 2196



ULC Listed, 2-hour fire-resistant cable, tested to ULC-S139

DESCRIPTION

This kit is used to make a fire-resistive field splice for nVent PYROTENAX System 1850 Mineral Insulated (MI) Cables. The process includes terminating the cables, splicing them together using a splice resistant to elevated temperatures, and covering the assembly with a fire-protection kit made of an endothermic matting.

For compliance with NEC (NFPA 70, 2014 edition) article 728.5F, this kit must be installed when joining two cable segments in the field if the intent is to create a two-hour fire-rated circuit.

The components supplied with this splice kit must be used to complete the splice. Substituting other materials or components will void the 2-hour fire-rating and approvals.

For technical support contact your nVent representative or call (800) 545-6258 for assistance.

TOOLS REQUIRED

- Sheathmaster sheath stripping tool for cables up to 3/4 in (1.9 cm) diameter or Ratchet Type stripping tool for cables larger than 3/4 in (1.9 cm) diameter
- Handvise
- Crimping and compression tool for the pot / fiber disc
- Pyropotter tool
- Medium grit Emery Cloth (80 to 180 grit)
- Allen key (see Pyropotter instruction for the size)
- Shielded twisted pair drain wire tool (for shielded twisted pair cable only)
- Open ended torque wrench
- Adjustable pliers / vise grips
- Jumper cable
- Multimeter or continuity tester
- Hacksaw
- Flat file
- Scribe or pick
- Permanent marking pen
- Clean dry cloth or rag
- Tape measure or ruler
- Crimping tool for crimp connectors (See Table 2 for details)
- 500 Vdc megohmmeter
- Safety goggles and gloves
- Oxy-acetylene or mapp gas torch (to dry out cable).
- Diagonal (side) cutter and tube cutter (if stripping cable sheath as shown in Appendix C)
- Caulking gun

WARNING:

This component is an electrical device that must be installed correctly to ensure proper operation and to prevent shock or fire. Read these important warnings carefully and follow all installation instructions.

- When MI cable is stripped and terminated, sharp metal edges can cause cuts and loose powder can cause eye irritation. To prevent

injury, gloves and safety glasses must be worn when carrying out these operations.

- Store all splice kit components indoors in a clean, dry area.
- To prevent burns when drying out the cable (Appendix D), allow it to cool until warm to the touch before completing the remaining termination instructions.

CAUTION:

HEALTH HAZARD. Consult your nVent representative or call (800) 545-6258 for MSDS safety information regarding the mastic sealing compound or endothermic mat.

MATERIALS REQUIRED

- Refer to the MI Cable Commercial Wiring Installation Manual, H57864, for complete details on installing System1850 MI cable.
- Adequate steel structural support in place for each finished splice. Cable tray or trapeze support spaced 16 to 18 in (410 to 460 mm) on center may be used for support. Alternate may be two 1-5/8 in (41 mm) min solid steel unistrut beams 8 in (200 mm) long mounted (or welded) onto vertical wall mounted struts at 90° and spaced 16 to 18 in (410 to 460 mm) on center. Refer to the MI Cable Commercial Wiring Installation Manual, H57864 for complete details on supporting and securing the Field Installed Fire Rated Splice.
- System 1850 MI Cable pulled to splice location and without bends or outer polymer jacket for 4 ft (1.2 m) either side of planned splice.

KIT CONTENTS: ALL CONFIGURATIONS

Item	Qty	Description
A	2	Brass gland connector
B	2	Brass self-threading pot
C	*	Mastic sealing compound
D	2	Spacer disk and insulating sleeving assembly
E	*	Crimp connector(s)
F	1	3M™ fire barrier sealant
G	**	3M Glass Cloth Electrical Tape 69
H	1	Torque tags
I	1	Copper barrel
J	*	High-temperature crimp connector sleeve(s)
K	1	Barrel sleeve
L	2	Cable sleeve

* Quantity depends on number of conductors

** Only for splicing single-conductor, 2 AWG and larger

ADDITIONAL KIT CONTENT FOR SHIELDED TWISTED CABLE

Item	Qty	Description
N	2	Drain Wire Ring Assembly
O	1	Popsicle Stick
P	1	Brass bushing

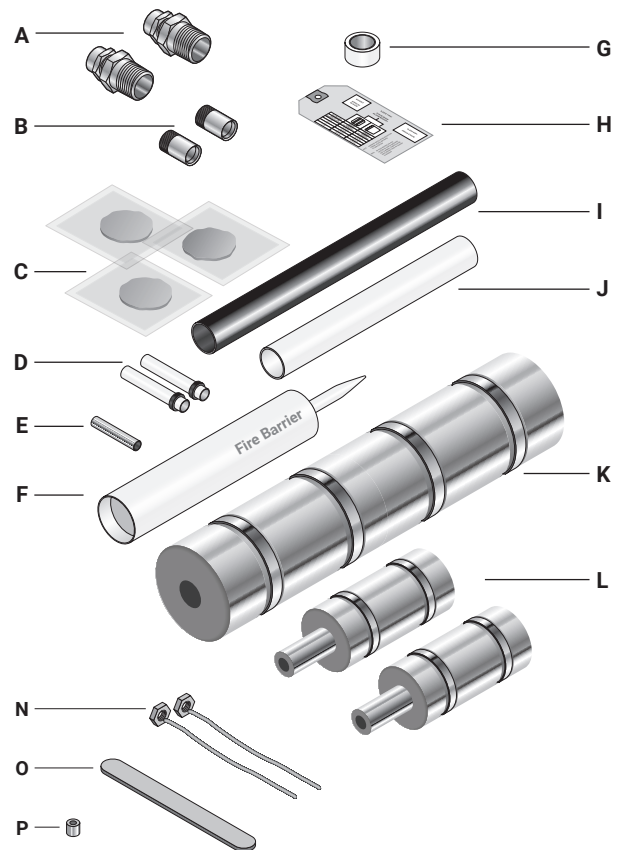

Important: The magnesium oxide insulation in mineral insulated cable will absorb moisture when exposed to air for any length of time. It is desirable, therefore, to immediately seal the end of the cable once started. If insulation resistance (IR) tests low, refer to Appendix D.

1

- Ensure that both ends of the MI cable are straight (4 ft - 1.2 m for each end). If the cable has a polymer jacket, also remove 4 ft (1.2 m) of the jacket from each end; the copper sheath must be visible.

Note: (jacketed cables only): Once the fire-rated splice assembly is complete, approximately 2-1/2 ft (75 cm) of bare cable will be exposed to the environment on either side of the splice. Consult your nVent representative or call (800) 545-6258 for means of protecting the exposed cable.

- With a hacksaw, cut the two ends (Side A and Side B) of the MI cable square and file the ends smooth.
- Place the three Fire-Protection Kit pieces (two cable sleeves and barrel sleeve) onto the cable as shown, followed by the gland connectors, followed by the copper barrel.

2

- Measure the outside diameter of the copper barrel. Locate the corresponding strip-back length in Table 1 and mark the MI cable sheath at length "L" shown in the table. This is the length of sheath to remove.
- If using the Sheathmaster sheath stripping tool, place a second mark 1 in (2.5 cm) behind this first mark as shown. If using the Ratchet Type stripping tool, place the second mark 1-1/2 in (3.8 cm) behind the first mark. The sheath will

Using Sheathmaster sheath stripping tool

1 in (2.5 cm) required for Sheathmaster sheath stripping tool (sheath will not be removed from this section)

Place first mark on cable for Strip-Back Length "L" from Table 1

Second mark

First mark

Sheathmaster tool

only be stripped back to the first mark exposing the solid conductor. The second mark from the end is used to position the handvise for final stripping.

- For details on using the Sheathmaster tool, refer to instruction H59039 supplied with the tool; for the Ratchet Type tool, refer to instruction H57842. An alternate method of stripping the cable sheath using a tubing cutter and side cutters is shown in Appendix C.

Using Ratchet Type stripping tool

1-1/2 in (3.8 cm) required for Ratchet Type Stripping Tool (sheath will not be removed from this section)

Place first mark on cable for Strip-Back Length "L" from Table 1

Second mark

First mark

Ratchet Type stripping tool

Table 1: Strip-Back Length, Tolerance $\pm 1/8$ in (3 mm)

Copper Barrel Size (NPT)	Copper Barrel Outside Diameter	Strip-Back Length "L"
3/4 in (19 mm)	1-3/16 in (30 mm)	3-1/2 in (89 mm)
1 in (25 mm)	1.55 in (39 mm)	3-3/4 in (95 mm)
1-1/4 in (32 mm)	1.96 in (50 mm)	4-1/8 in (105 mm)

3

- Instructions, Steps 3 through 26, apply to terminating both ends of cable. Complete the termination on one side before beginning the other.
- Grip the cable with the Handvise
- Using the sheath stripping tool (Ratchet Type tool shown), begin stripping the copper sheath back towards the first mark.
- After the first 1/2 inch (13 mm) of the outer sheath has been removed, make sure that the blade did not cut into the inner conductors or into the inner sheath in the case of the Shielded Twisted Pair Cable. Adjust the blade depth if necessary to avoid scoring the conductors or cutting the inner sheath.

 **Note: If splicing Shielded Twisted Pair Cable, ensure that the blade does not cut the inner sheath.**

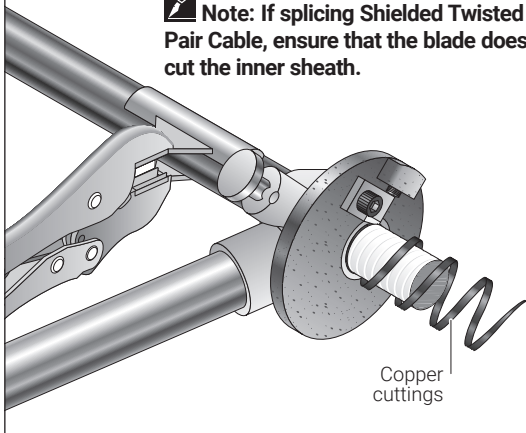

4

- For final stripping, grip the cable with the Handvise at the second mark. When the stripping tool touches the edge of the Handvise, it will stop and make a clean cut on the cable sheath at the first mark. At this point, the correct length "L" of solid conductor will have been exposed; if splicing Shielded Twisted Pair Cables, the inner shield will be exposed.
- For standard cables, proceed to Step 8. For Shielded Twisted Pair Cables proceed to Step 5.

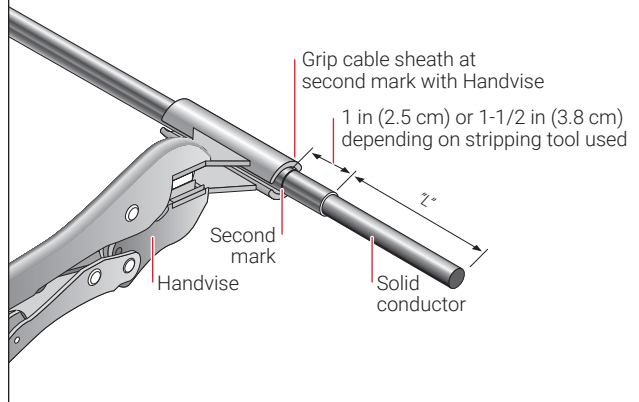

5 (for Shielded Twisted Pair Cables only)

- Insert the brass bushing supplied with the termination kit into the Sheathmaster tool, making sure that it is flush with the guide blocks at the blade end of the tool.
- Tighten the guide block to lock the bushing in place.

Tighten until snug

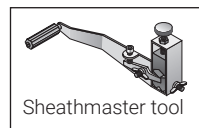

Sheathmaster tool

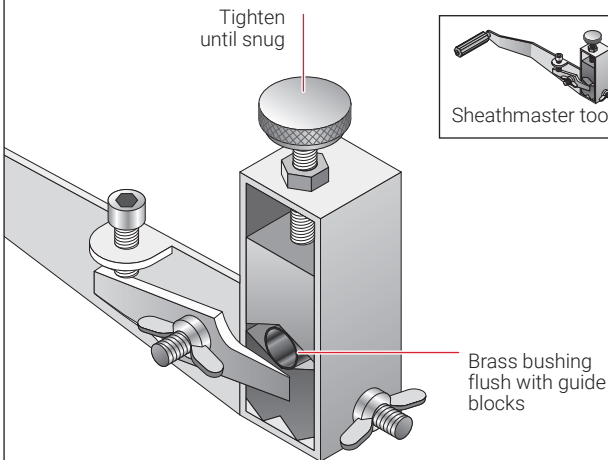

6 (for Shielded Twisted Pair Cables only)

Next, strip the inner shield back to accommodate the drain wire nut as follows:

- Wipe the shield with a clean dry cloth to remove loose powder.
- Strip the shield until the inside edge of the bushing contacts the outer sheath. While stripping the shield, reposition the Handvise as necessary to prevent the shield from bending. When the bushing meets the outer sheath, turn the handle another 360 degrees so that the cutting breaks free.

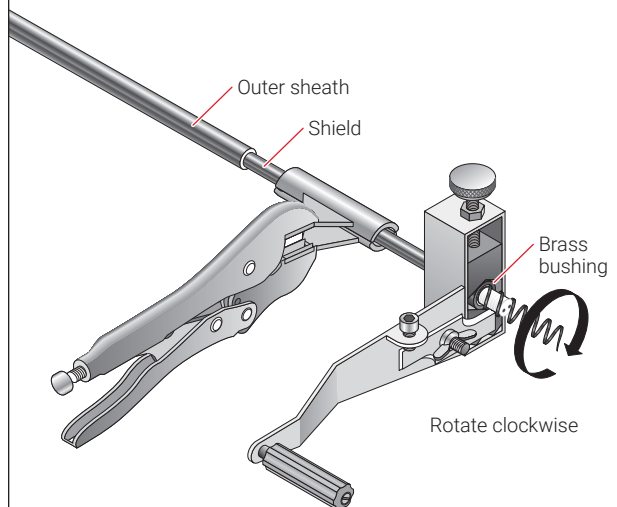

7 (for Shielded Twisted Pair Cables only)

- Remove sheath stripping tool; 11/32 in (9 mm) of the shield and about 3-5/32 in (80 mm) of the twisted conductors (or tails) should be left protruding from the end of the cable.

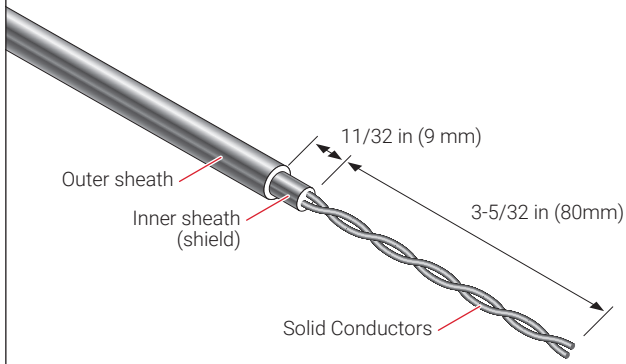

8

- For all cables, straighten the conductors. For multi conductor cables, including Twisted Pair Cables, ensure that the conductors are evenly spaced.
- Clean the conductors with a clean, dry rag or cloth to remove loose powder from the conductors. Next, polish all around entire length of solid conductors and 2 in (5.0 cm) of sheath behind the conductors with emery paper to achieve a clean surface.
- Visually inspect the magnesium oxide insulation at the face of the cable for traces of copper filings and burrs and if present, gently remove with a pick.

Note: If using a pick to remove copper filings from the face of the cable, do not remove more powder from the face of the cable than is necessary.

Note: Do not blow out copper filings that may be present in the MgO powder as this can introduce moisture into the end of the cable, resulting in decreased insulation resistance.

Note: Only polish the cable sheath: do not sand excessively as reducing the sheath thickness will prevent the self threading pot from grabbing onto the cable.

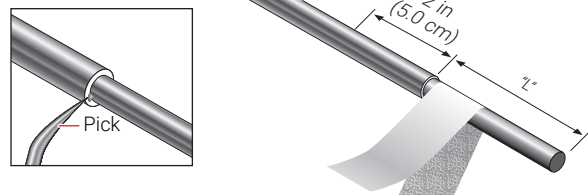

9

- Place a mark at a length "E" (refer to table below) from end of cable (outer) sheath. The pot will be screwed on to the cable sheath so that the back of the pot aligns with the mark.

Pot (Barrel) Size	Length "E" to mark
3/4 in (19 mm)	7/16 in (11 mm)
1 in (25 mm)	9/16 in (14 mm)
1-1/4 in (32 mm)	5/8 in (16 mm)

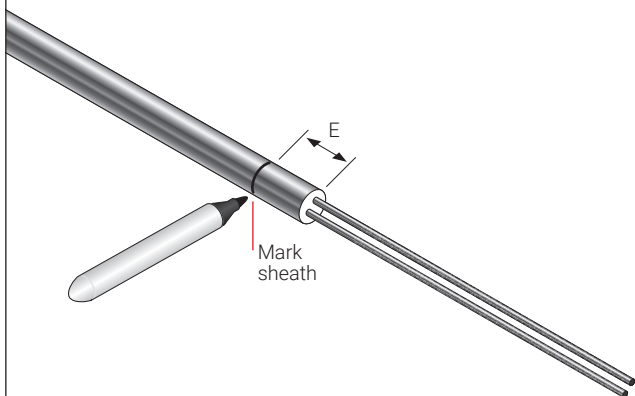

10

- Place the self-threading pot into the non-threaded end of the Pyropotter tool with the larger hole of the pot facing outwards and protruding past the end of the tool by the length shown in the table. Refer to Pyropotter tool instruction H59038 for details on using the tool.

Pyropotter Size	Length of pot protruding
3/4 in (19 mm)	3/8 in (9.5 mm)
1 in (25 mm)	3/8 in (9.5 mm)
1-1/4 in (32 mm)	5/8 in (16 mm)

- Next, tighten the Allen screw on to the pot. Use a 3/16 in Allen key for the 3/4 in Pyropotter tool and a 5/16 in Allen key for the 1 in and 1-1/4 in Pyropotter tool.

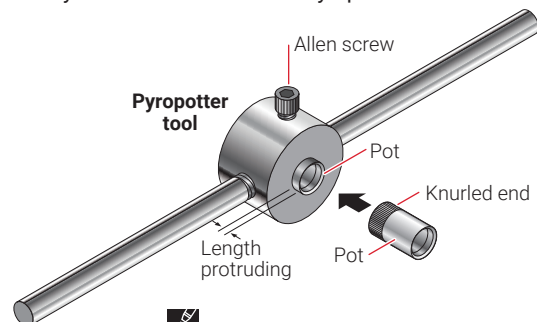

Note: Ensure that the Allen screw is tightened onto the knurled end of the pot.

11

- Slide the assembly over the exposed conductors, threaded end of Pyropotter first, until it stops at the face of the cable.
- Screw the gland connector (already on the cable) all the way into the threaded end of the Pyropotter tool; finger-tight is sufficient.

 **Note:** This step perfectly aligns the pot with the cable.

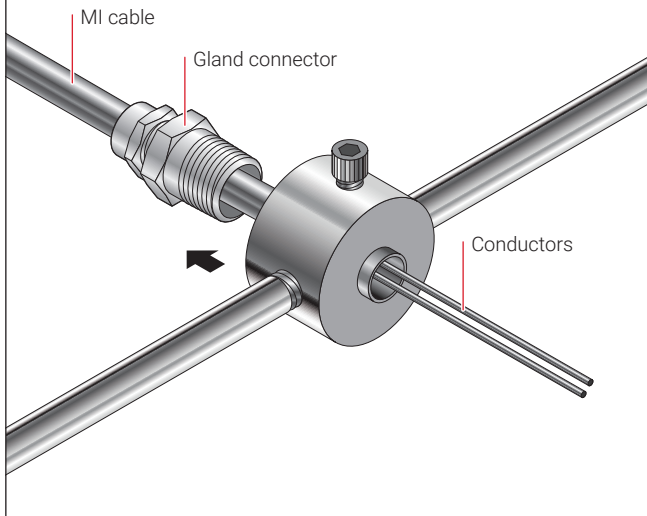

12

- Turn the Pyropotter tool in a clockwise direction while simultaneously applying light pressure. This will engage the internal screw thread of the pot onto the sheath of the MI cable.

- Continue rotating the assembly until the end of the copper sheath projects 1/8 inch (3 mm) inside the pot.

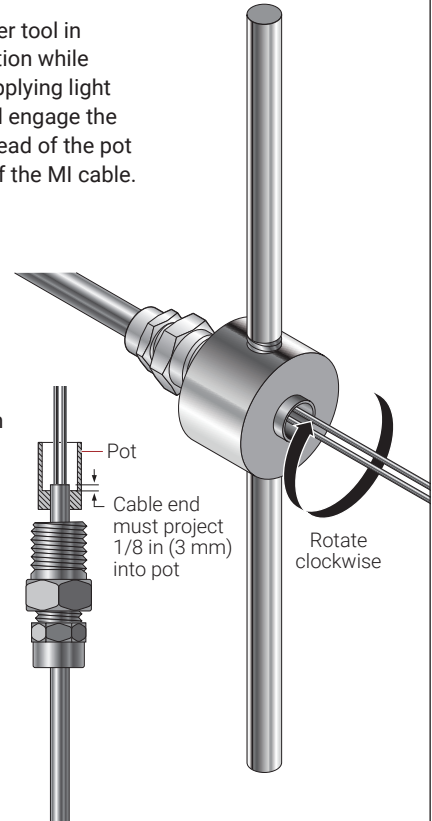

13

- To remove the tool, hold the gland connector firmly in one hand and rotate the tool in a counter-clockwise direction. This unlocks the Pyropotter tool from the gland/pot assembly and permits the easy removal of the tool from the cable.

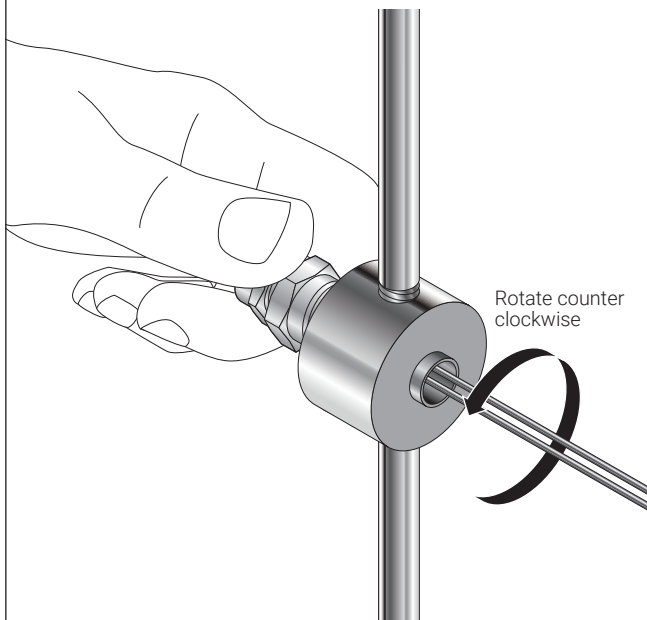

14

- Verify that the back of the pot aligns with the mark made on the copper sheath in Step 9. If the pot is behind the mark on the cable, vise grips may be used to screw the pot to the mark.

 **Important:** Cable end must project 1/8 in (3 mm) into pot in order to make an effective seal.

- Check inside of the pot for loose filings and remove them with a small tool or a pick. Do not remove more powder than is necessary.

 **Note:** Do not blow out copper filings (in the MgO or in the pot) as it can introduce moisture into the end of the cable, resulting in decreased insulation resistance. A bulb syringe may be used instead.

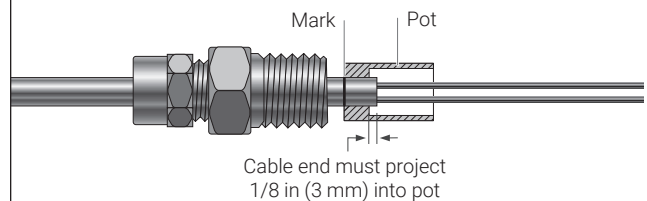

If splicing Shielded Twisted Pair Cables, continue with Steps 15 and 16, otherwise continue with Step 17.

15 (for Shielded Twisted Pair Cables only)

If splicing Shielded Twisted Pair Cables, install the drain wire nut onto the shield of the MI cable as follows:

- Insert the drain wire nut into the hex wrench of the drain wire tool with the drain wire down the center of the tool.
- Insert the twisted pair conductors through the hole in the nut and the center of the drain wire tool.

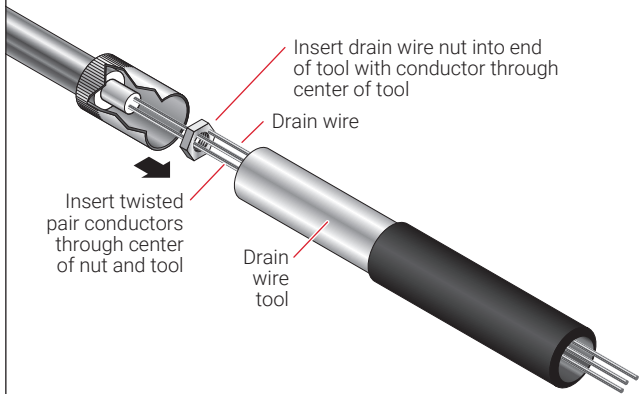

16 (for Shielded Twisted Pair Cables only)

- Screw the drain wire nut onto the shield of the MI cable stopping when the top of the drain wire nut is flush with the end of the shield.
- Align the drain wire nut/wire by turning it to a position 90 degrees from the two conductors.

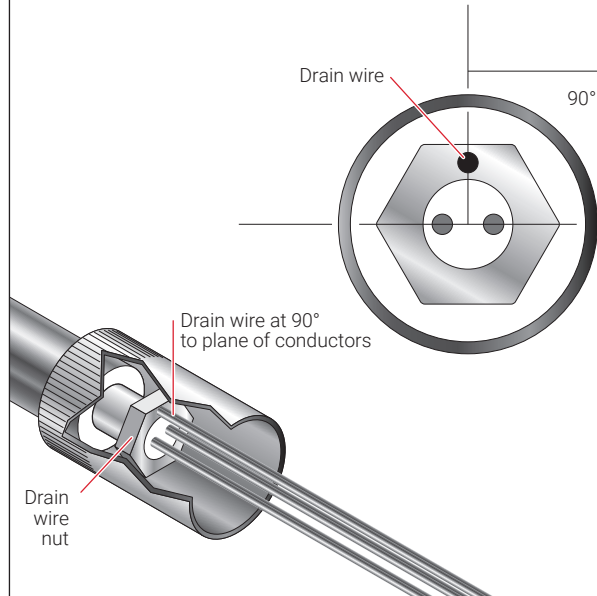

17

- If terminating a single conductor cable or the first end of a multiconductor cable, proceed to Step 18. If terminating the second end of a multiconductor cable, you must first test the end-to-end continuity of the conductors with a continuity tester or multimeter to identify the matching conductor at both ends.
- Mark the matching conductor at both ends to provide identification. Once the termination is complete, vinyl cloth wire markers may be used at both ends of the cable for permanent identification. The procedure to identify matching conductors at the cable ends is shown in Appendix B.

Important: Small ~ 0.2 in x 0.2 in (5 mm x 5 mm) vinyl cloth wire markers may be used to identify conductors. Do not use any other type of wire markers.

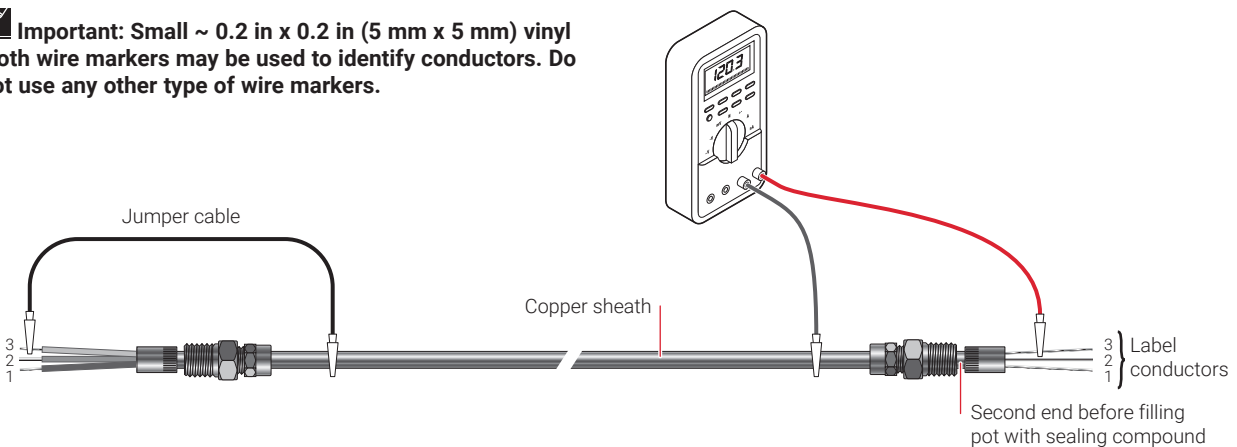

- Using a 500-Vdc megohmmeter, check the insulation resistance (IR) of the cable to ensure it is free of grounds and shorts. Check IR between conductor(s) and sheath, and between each pair of conductors. See Appendix A for detailed test procedure and IR test criteria.

Note: Low IR results indicate that moisture is present in the end of the MI cable and must be removed before termination. If neither cable end has yet been terminated and IR readings are low, dry out both ends following the procedure in Appendix D or cut of shorted end and retest. Once IR readings are satisfactory, continue to the next step.

Note: Opposite end of cable must also be dry and free of grounds and shorts to obtain an acceptable IR reading.

- If moisture was removed from the end of the cable using the procedure in Appendix D, allow the cable to cool until warm to the touch and continue with the steps to seal the end of the cable.
- Once IR readings are satisfactory, immediately apply the mastic sealing compound as described in the steps following. A delay will cause the IR to drop and the cable must be retested prior to sealing the end.

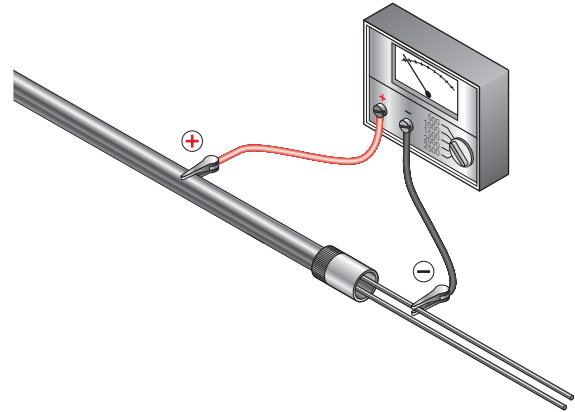

- Slide spacer disc and insulating sleeving sub-assembly over conductors, anchoring bead end first.
- Complete the following steps immediately to ensure that the end is properly sealed with mastic compound.

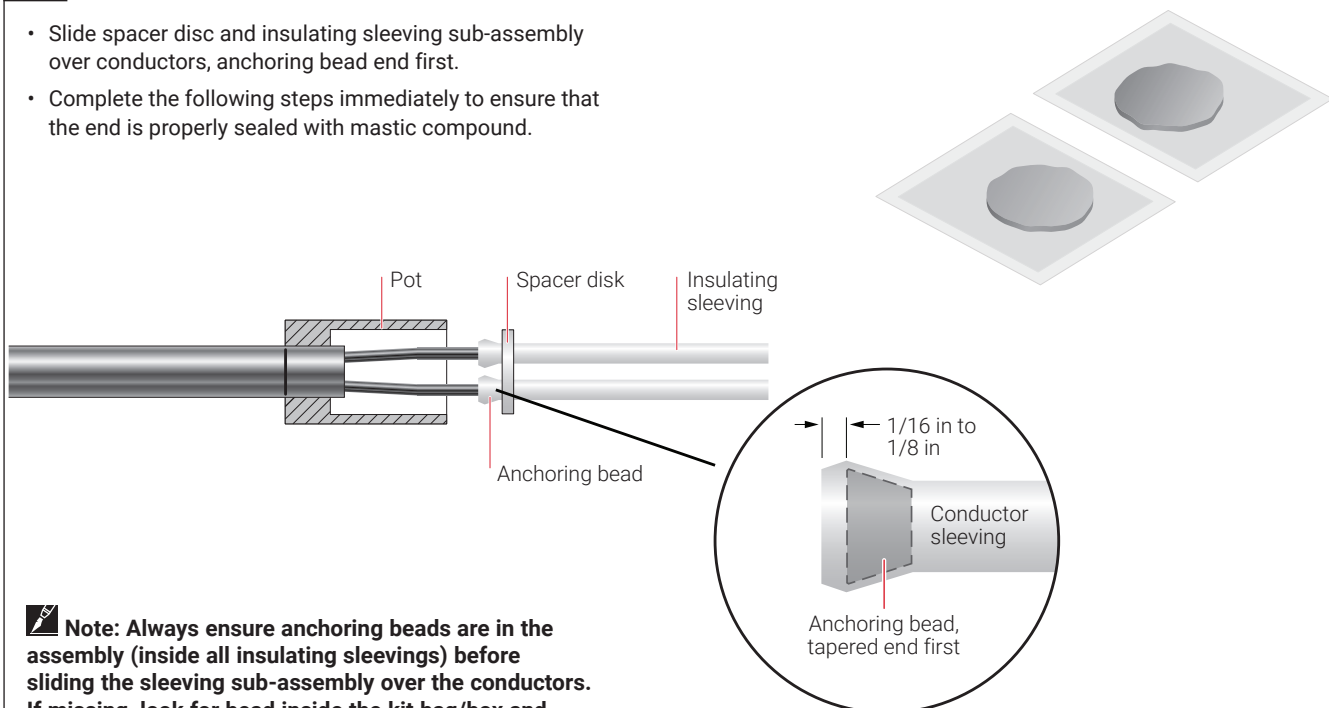

Note: Always ensure anchoring beads are in the assembly (inside all insulating sleeveings) before sliding the sleeving sub-assembly over the conductors. If missing, look for bead inside the kit bag/box and re-insert the bead into the sleeving, tapered end first. Push the bead in so that it is entirely covered by the sleeving but is not pushed beyond 1/16 in to 1/8 in past the sleeving end.

- Withdraw spacer disk and sleeving sub-assembly slightly to allow sealing compound to be packed into the pot.
- Ensure conductors are spaced an equal distance apart from each other and the inside of the pot.
- The pot should still be warm following the drying out procedure, if not, heat the cable and then the pot with the torch until just warm to the touch before filling with mastic sealing compound.
- Open the mastic compound package on three sides. Do not allow compound to become contaminated with any foreign matter once package is opened. Press mastic sealing compound into pot with thumb behind the wrapper to ensure cleanliness, pressing from one side only to prevent air pockets.

Note: Store mastic sealing compound at room temperature or an inside shirt pocket until ready to use. Mastic compound may be installed as low as 14°F (-10°C) providing compound is kept warm prior to use.

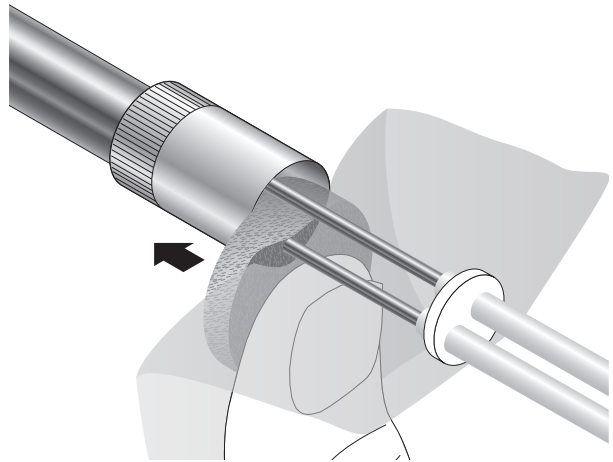

21 (for Shielded Twisted Pair cables only)

- Using the popsicle stick provided, tamp the compound down between the pot and the drain wire nut to ensure the cable end beneath the nut is well covered and free of air pockets.

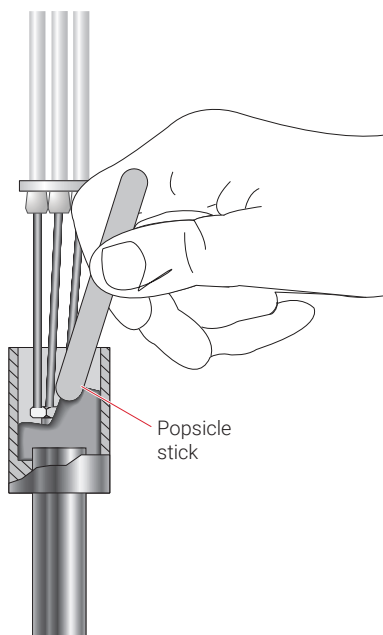

22

- Continue filling the pot until the Mastic sealing compound comes out the opposite side of the pot and the pot is slightly overfilled.

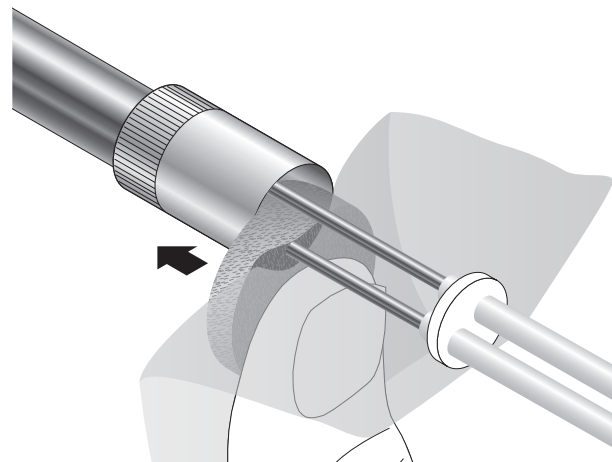

23

- Using a screwdriver or other tool, push spacer disk into open end of the pot. Pull gently on the sleeving to ensure the anchoring beads are snug against inside face of the spacer disk. Do not push on the sleeving as it may be forced back through the cap and butt against the end of the cable, preventing the compound from making an effective seal.

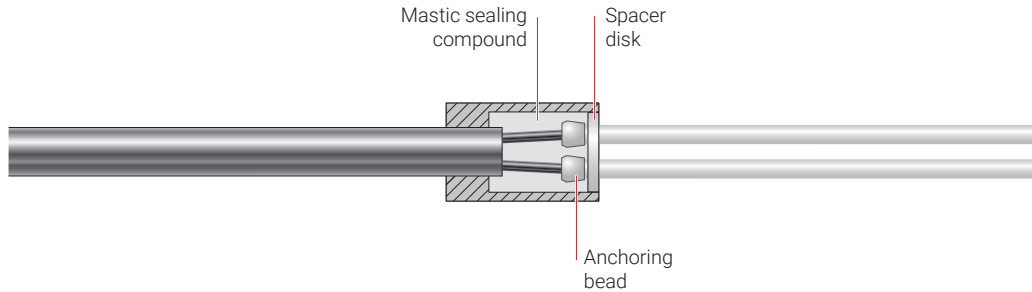

24

- Place the pot into the body of the crimping and compression tool (hand adjustable type shown) making sure that the sleeving is inserted through the center of the MI crimping tool. The end of the pot with the spacer disk must fit inside the three cone shaped points on the crimping plate of the MI Crimp tool.

Note: Hold the tool firmly, with vise grips if needed, to prevent the tool from turning the pot.

- Apply even pressure on the spacer disk by tightening the tool until the spacer disk is snugly seated inside the opening of the pot and the cone-shaped points have crimped the side of the pot. This will retain the spacer disk in position. The termination is now complete.

Note: It's normal for the mastic seating compound to squeeze out the side of the pot as pressure is applied with the crimping and compression tool.

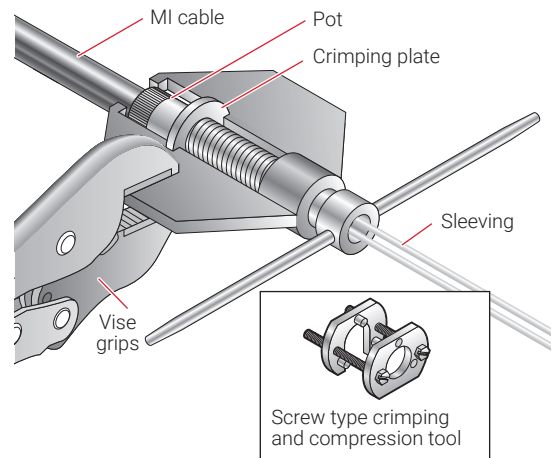

25

- On completion of the termination, check the IR again with the 500-Vdc megohmmeter (see Appendix A).

Note: Under adverse weather conditions, IR readings may be lower than the values shown in Appendix A.

- If the other end of the cable has not yet been terminated, complete the termination following the same procedure.

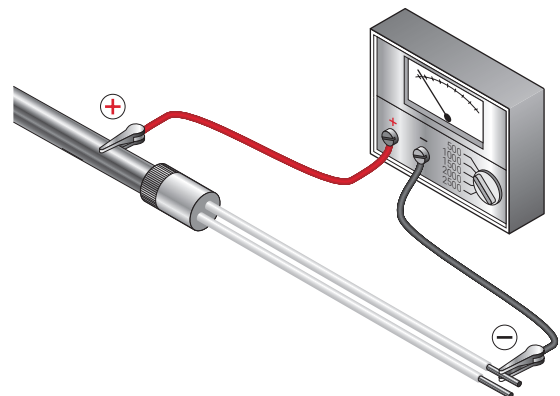

Table 2: Crimp Connector Die Selection

Conductor Size AWG/kcmil	ILSCO Die Color Code	ILSCO Hex Die Index	Manufacturer Part No.	No. of Crimps per End	Tool Required (or equivalent)
16	—	(T&B crimp die nest B)	2B-14	1	ERG4002
14	—	(T&B crimp die nest B)	2B-14	1	ERG4002
12	—	(T&B crimp die nest C)	2C-10	1	ERG4002
10	—	(T&B crimp die nest C)	2C-10	1	ERG4002
8	Red	—	CT-8	1	ILC-10-N
6	Blue	—	CT-6	2	ILC-10-N
4	Gray	—	CT-4	2	ILC-10-N
3	Gray	—	CT-3	2	ILC-10-N
2	Brown	—	CT-2	2	ILC-10-N
1	Green	4	A8140	2	ILC-12-N
1/0	Pink	5	A8141	2	ILC-12-N
2/0	Black	6	A8142	2	ILC-12-N
3/0	Orange	9	A8143	2	ILC-12-N
4/0	Purple	10	A8144	1	ILC-12-N
250	Yellow	11	A8145	2	ILC-12-N
350	Red	13	A8146	1	ILC-12-N
500	Brown	15	A8147	2	ILC-12-N

Note: Only ILSCO hex dies are to be used where die is specified. Failing to do so will void the connector approval and could result in splice failure.

Note: Connector must be crimped using tools as listed in the table above. Other equivalent tools may be used provided that they can accept the required ILSCO dies. For conductor sizes 1 AWG and larger, the following approved ILSCO die type tools may also be used: ILC-12, ILC-12-N, ILC-12H, ILC-12H-N, ILC-14, or ILC-14H.

26

- Clean bare conductor ends with emery cloth to make good electrical connections. Place crimp connector over bare conductor of one end ensuring end of conductor goes all the way to the center stop of the crimp connector.
- Using approved die type hydraulic compression tool or hand tool as appropriate (see Table 2), with the correct die color code, crimp connector on to conductor using 1 or 2 crimps per end as indicated in Table 2 for the specific conductor size.

Important: Where multiple crimps required per end, make the outside crimp first.

Important: Inspect the crimp connector for any burrs or sharp edges, and remove them with a flat file (or for smaller cables, using side-cutters).

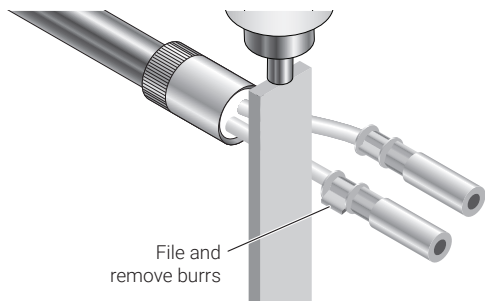

27

Important: Ensure that all exterior Fire Protection Kit components have been placed onto the cable in the correct order before proceeding to this step (see Step 1 for details).

- Push high-temperature crimp connector sleeves over the crimped end(s), past the crimp itself, and hold it in place. The sleeve will compress lengthwise like an accordion.
- Push the other cable segment's associated conductor into other end of crimp connector(s) and crimp as in previous step.

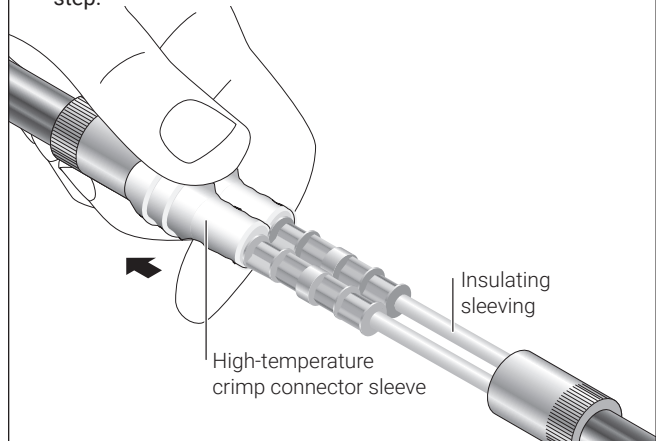

- Slide the high-temperature crimp connector sleeves back over the crimp connector such that it is centered between pots as shown in the illustration below.
- For all cables except single conductor 2 AWG and larger, the connector sleeve will cover the entire conductor length (including crimp connector), pot to pot.

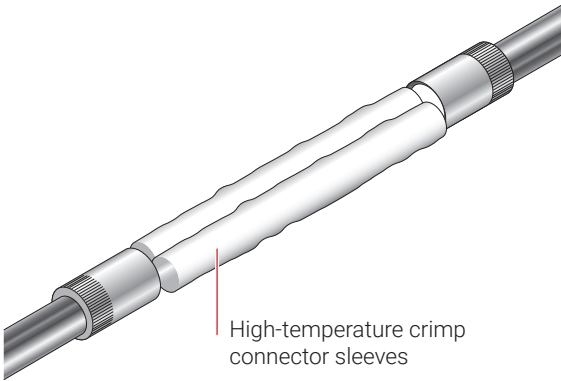

- For 2 AWG and larger single conductor cables, the crimp connector sleeve will be shorter than shown in the previous illustration and must be held in place using glass cloth tape. Center the crimp connector sleeve over the crimp connector before taping. Each end of the crimp connector sleeve is to be taped to the insulating sleeving to seal the ends, so as to create a minimum of two layers of tape as shown in the illustration.
- Use half overlaps for each turn.

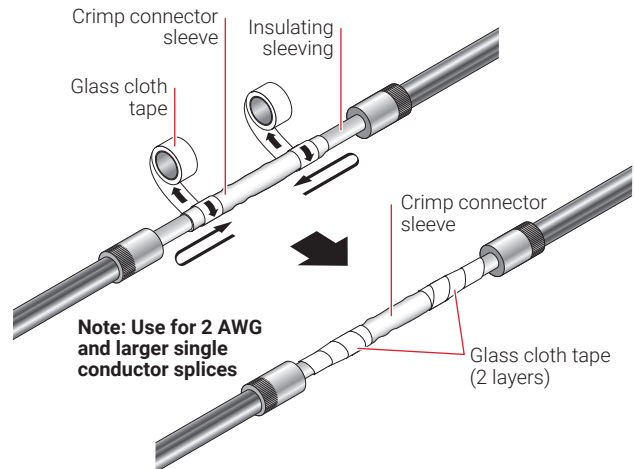

- Mark the cable 6 in (150 mm) from the back of either pot as shown in the illustration.
- Screw one gland connector into the end of the copper barrel (hand-tight only), then slide the barrel over the splice.
- ⚡ **Important: Do not tighten compression nut at this time.**
- Screw the other gland connector into the remaining end of the barrel, again, hand-tight only.

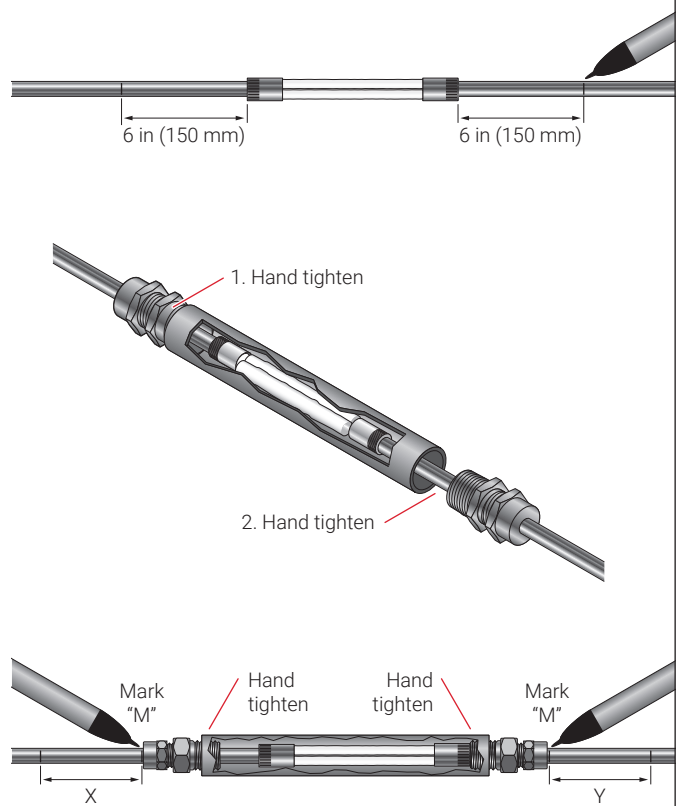

- Ensure the barrel is centered over the splice. This can be accomplished by centering the barrel/gland connector assembly between the two marks made earlier in this step (length "X" and "Y" should be equal).
- Place additional marks "M" on the cable sheath directly behind the gland connectors. These 2 marks will be used to ensure the splice remains perfectly centered in the next two steps.

30

- Using a wrench, tighten both gland connectors, one at a time, into the copper barrel. Use a second wrench to hold the gland connector on the opposite end while tightening the first gland connector.

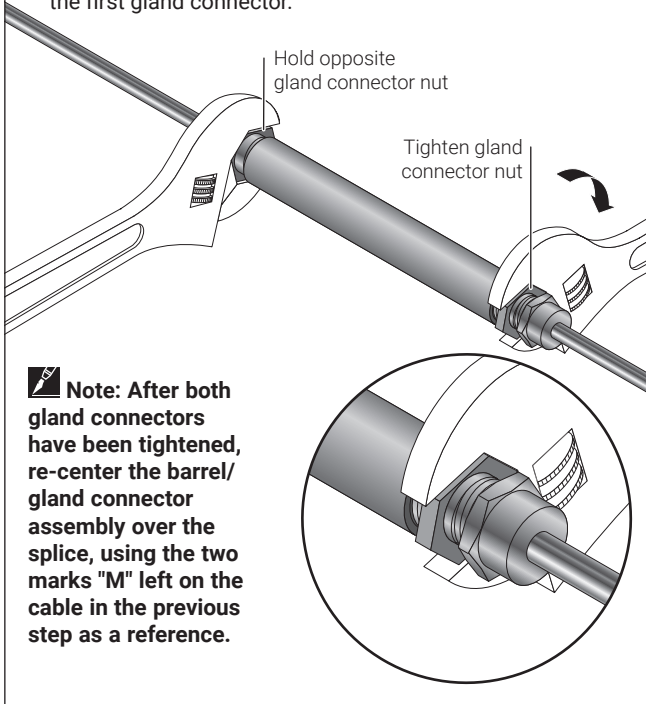

Note: After both gland connectors have been tightened, re-center the barrel/gland connector assembly over the splice, using the two marks "M" left on the cable in the previous step as a reference.

31

- Tighten the compression nut on both gland connectors per the recommendation on the supplied torque tag (25 ft-lbs). The joint is now complete.

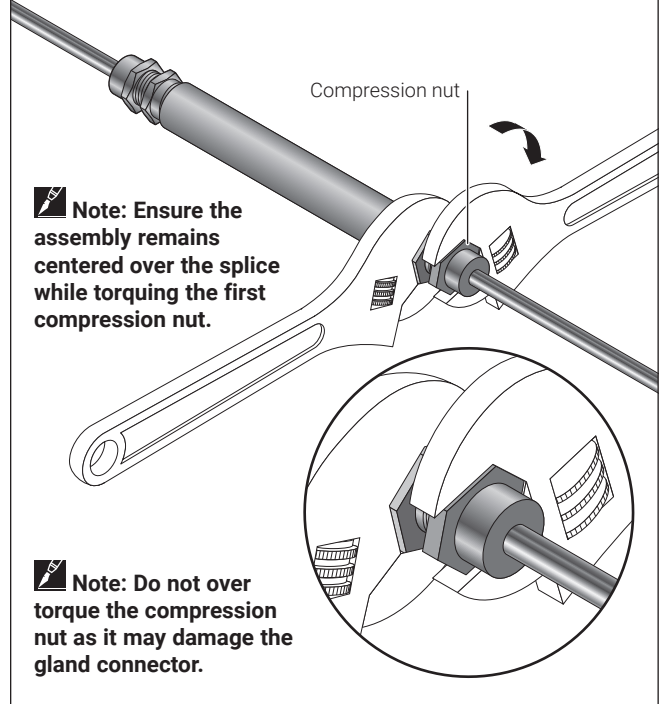

Note: Ensure the assembly remains centered over the splice while torquing the first compression nut.

Note: Do not over torque the compression nut as it may damage the gland connector.

32

- Install the barrel sleeve such that it is centered over the splice. Insert the cable sleeves into the open ends of the barrel sleeve until they come to a stop. There should be no space between the ends of the barrel sleeve and the thicker section of the cable sleeves. If a space exists, adjust the position of the barrel sleeve (re-center) so the space disappears.

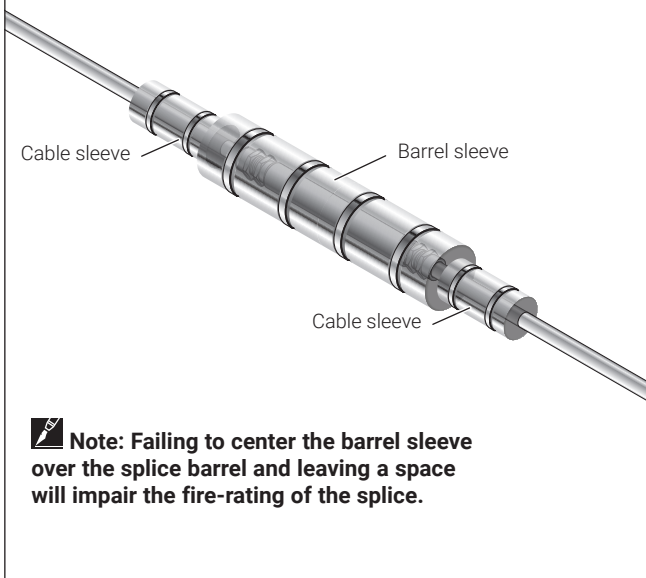

Note: Failing to center the barrel sleeve over the splice barrel and leaving a space will impair the fire-rating of the splice.

33

- Once the barrel sleeve is centered, remove the cable sleeves. Apply a 1/2" bead of the 3M fire barrier sealant to the cable inside the barrel sleeve and to the cable sleeve where it enters the barrel sleeve. Apply 3M fire barrier sealant to fill all visible gaps between the barrel sleeve and the cable sleeves, and to cover all exposed (white) 3M Interam™ material. Use only the 3M fire barrier sealant FD 150+ supplied with this splice kit.

The sealant is applied to a minimum wet thickness of 1/8 in. and may be brushed or troweled to achieve the desired uniform thickness.

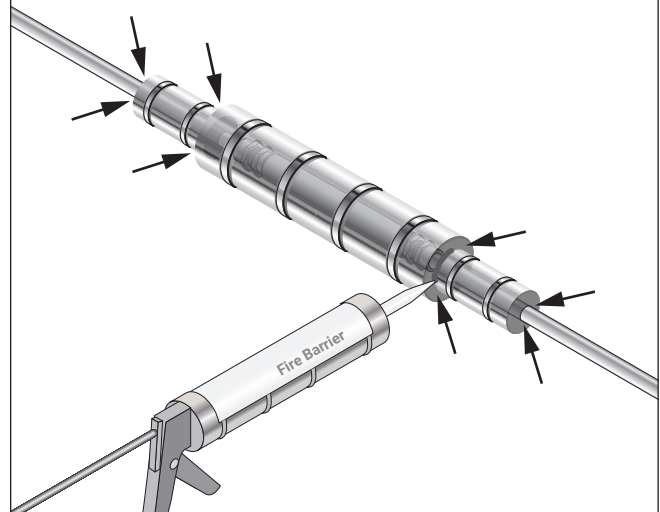

- The illustration below shows a typical completed, installed, 2-hour fire-rated splice including its support system. Refer to the MI Cable Commercial Wiring Installation Manual, H57864, for complete details on installing System 1850 MI cable.

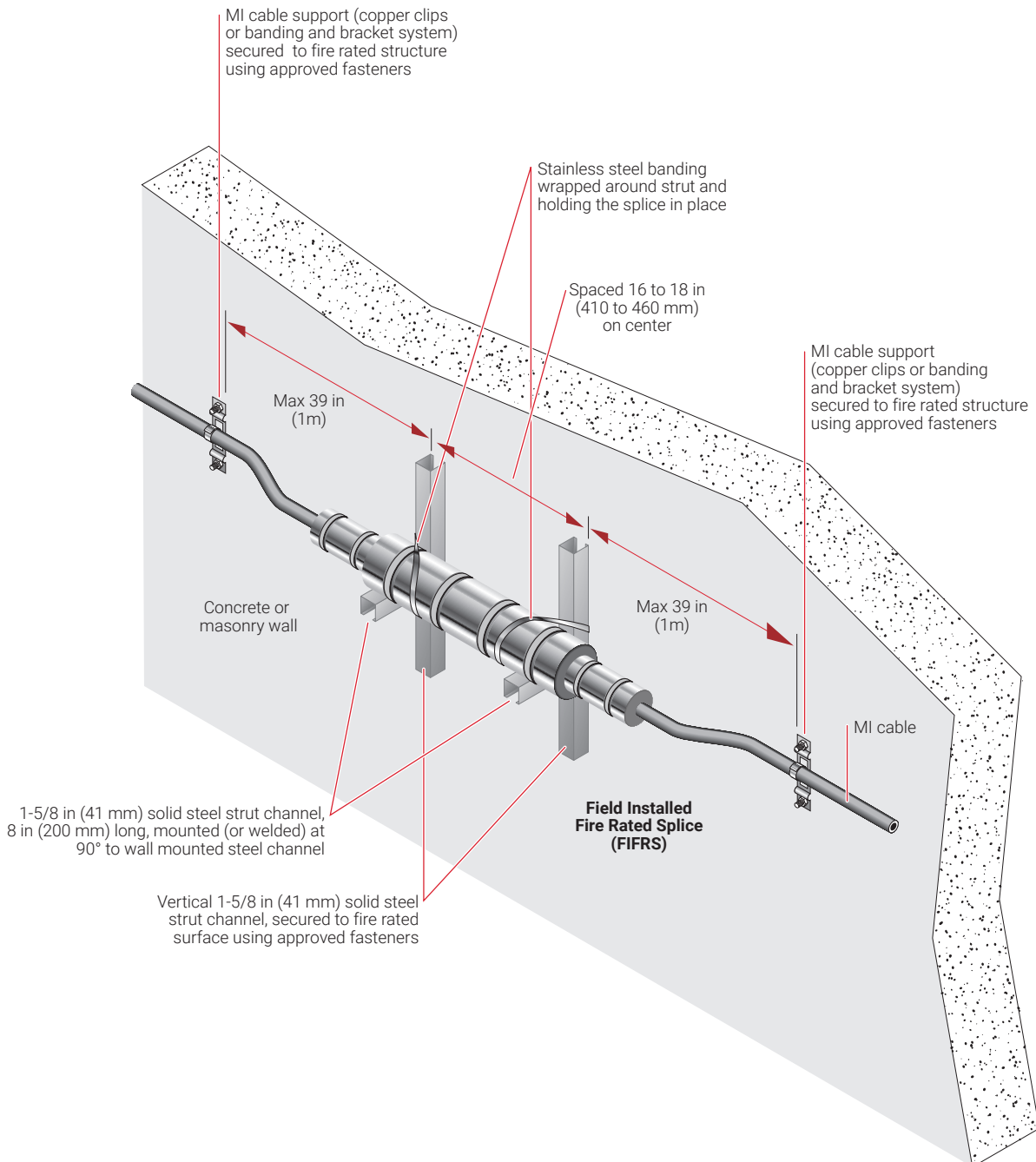

Note (polymer jacketed cables only): once the fire-rated splice assembly is complete, approximately 2-1/2 ft (75 cm) of bare cable will be exposed to the environment on either side of the splice. If necessary, consult your nVent representative or call (800) 545-6258 for means of protecting the exposed cable.

Appendix A: Insulation Resistance (IR) Test

Test Equipment

500-Vdc Megohmmeter

IR Testing

IR testing is conducted using a megohmmeter and tests the integrity of the cable between the conductor and the copper sheath and between conductor pairs.

Test Criteria

When received:

- Check cable on reel. Note that ends may need to be prepared to allow insulation resistance (IR) readings to be taken. IR readings must not be less than 200 M Ω under any conditions.

After installing termination kit:

- In a warm, dry environment, IR readings should be 200 M Ω or higher.
- In an outdoor environment or indoors in wet or humid conditions, IR readings should all be above 100 M Ω .
- Similar cables exposed to similar conditions should all have IR readings in the same general range. Where a large difference in readings is encountered, high readings can be accepted; low readings (below 100 M Ω) should be checked as described below.

Note: Under some installation conditions it may not be possible to obtain IR readings above 100 M Ω . If IR readings are between 25 M Ω and 100 M Ω , wait 24 hours and recheck the IR using the same equipment. If the IR reading has not decreased, the termination is good - a constant low IR reading can result from moisture entrained in the cable while making a good seal; this moisture will not increase. If the IR reading has decreased, the cable must be re-terminated - a low IR reading can result from a poorly made seal which will allow continuing moisture ingress, requiring that the termination be redone.

If the IR reading is less than 25 M Ω , the cable must be re-terminated following the "drying out" procedure in Appendix D.

Test Procedure

1. Set megohmmeter test voltage at 0 Vdc or off.
2. Connect the positive (+) (earth) lead to the cable sheath.
3. Connect the negative (-) (line) lead to the conductor.
4. Turn on the megohmmeter and set the voltage to 500 Vdc; apply the voltage for one minute. Meter needle should stop moving. Rapid deflection indicates a short. Note the insulation resistance value. It should correspond to the values shown under Test Criteria.
5. Turn off the megohmmeter.

WARNING: Shock Hazard. The MI cable can store a large electrical charge after the insulation resistance test is performed. To prevent personal injury from electrical shock, fully discharge the cable prior to disconnecting the megohmmeter. Many meters will discharge automatically. However, it may be necessary to short the cable leads. Contact your supervisor or the instrument manufacturer to verify the safest practice.

6. If the megohmmeter does not self-discharge, discharge phase connection to ground with a suitable grounding rod. Disconnect the megohmmeter.

Note: Depending on the type of cable being tested, you will need to repeat the steps in this procedure for each of the conductors present in the MI cable. Also repeat testing for all conductor pair combinations (i.e. connect the leads from the megohmmeter to each conductor pair). If IR readings are low, follow the drying out procedure in Appendix D.

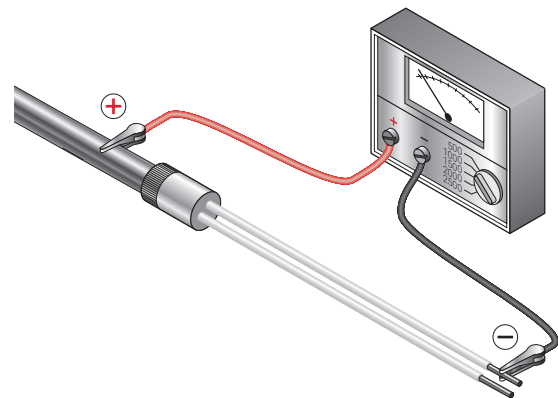

Appendix B: Identifying Conductors

Note: If one end of the cable has been terminated, the conductors should be rung out with a continuity tester (or multimeter) to identify the matching conductor at both ends.

- 1 Start with the end of MI cable which has just been terminated. Connect one end of a jumper cable to one of the conductors and the other end to the outer copper sheath of the cable (see Figure 1). Alternately, electrical tape may be used to connect the conductor to the cable sheath.
- 2 Ensure that the test leads are placed into the correct terminals on the multimeter; the black test lead connects into the common or black terminal and the red test lead into volts/ohms terminal.
- 3 Turn the multi-meter on. If your multi-meter does not automatically change settings, set it to the lowest "Ohms" setting.
- 4 On the other end of the MI cable which has not been sealed, clip the black lead to the outer copper sheath of the MI cable. Now, alternately touch the red lead from the multi-meter to each conductor.
- 5 When you touch the matching conductor (i.e. the conductor shorted to the sheath on the other end), the multimeter will indicate a low "Ohms" reading. The resistance of all other conductors should show infinity or "OL" (overlimit).

Mark the matching conductor at both ends to provide identification. Once the termination is complete, vinyl cloth wire markers may be used at both ends of the cable for permanent identification.

- 6 Repeat the above procedure to identify all of the conductors in the MI cable (i.e. move the jumper cable to the next conductor and repeat the procedure to identify the same conductor on the other end).

Important: Small ~ 0.2 in x 0.2 in (5 mm x 5 mm) vinyl cloth wire markers may be used to identify conductors. Do not use any other type of wire markers.

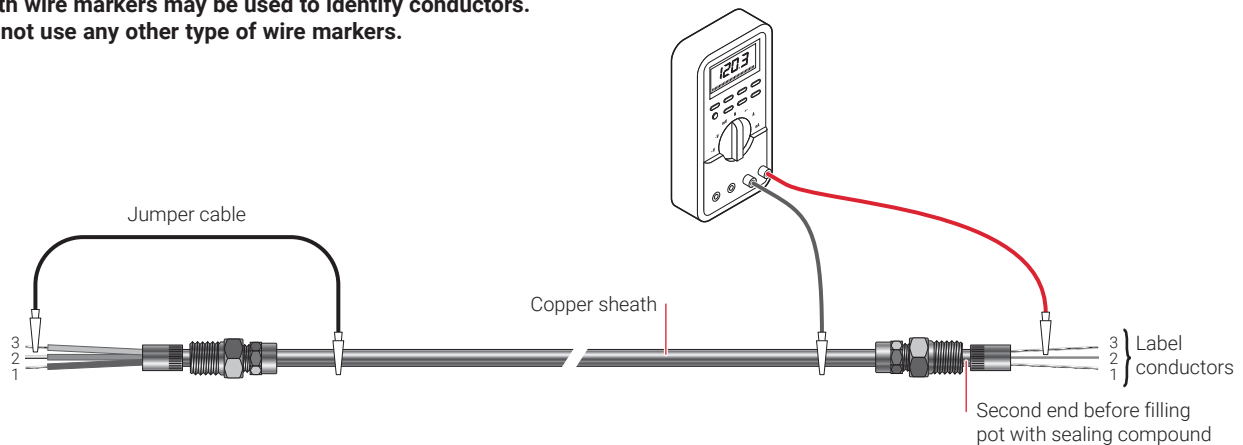

Appendix C: Stripping nVent PYROTENAX Copper Sheath MI Cable

Using diagonal cutters

Measure, from cable end, length of cable sheath to strip and mark sheath with marking pen. Use a tube cutter to score around the sheath at the mark. This will cause the sheath to peel away at the score providing a smooth end when the sheath is stripped. The correct depth of score is half the thickness of the sheath.

Do not cut completely through the cable sheath as this will cause the sheath to curve inwards toward the conductor(s).

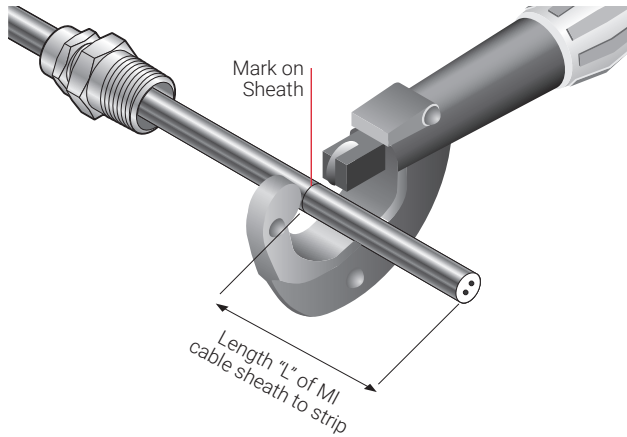

Hold the cable with the hand vise behind the score on the sheath. Grip the edge of the sheath between the jaws of the side cutters and twist clockwise (twist counter-clockwise if left-handed), then take a new grip and rotate through a small angle.

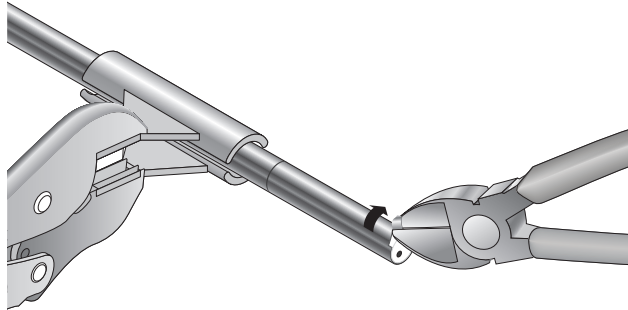

Continue this motion in a series of short "rips", keeping the side cutters at about 45° to the line of the cable, removing sheath spirally. Remove compacted powder insulation to expose conductors.

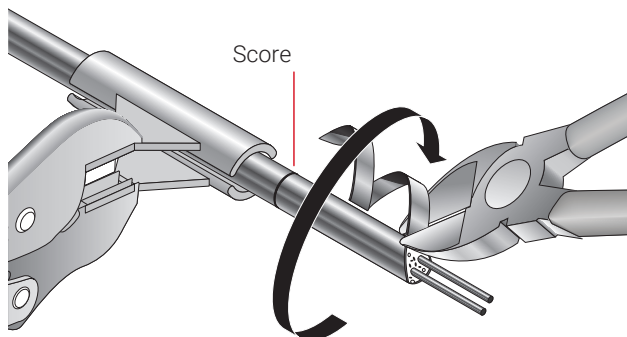

Continue removing the sheath to the score mark. When about to break into the score, bring side cutters to right angle with cable. Finish off with point of side cutters held parallel to the cable. The sheath will peel away leaving a clean cut when the score mark is reached.

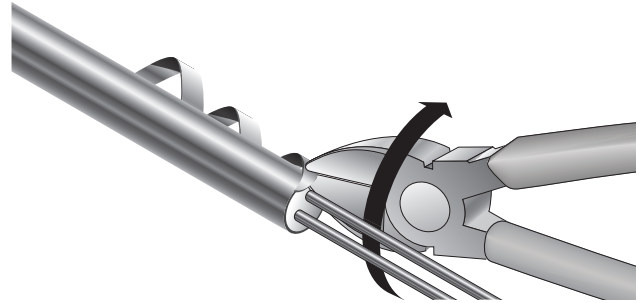

The cable sheath is correctly stripped, with the sheath flared slightly outwards, as shown in (a).

In (b) the sheath is neither flared outwards nor beveled inwards, but is acceptable.

Ensure that the sheath is not curved or beveled inward as shown in (c). This will occur if the score made with the tube cutter is too deep. In this case, remove a further 1/4 in (6 mm) of sheath. Cable is now ready to be sealed.

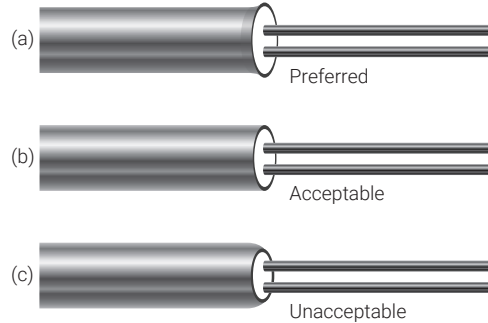

Appendix D: Improving Insulation Resistance

To maintain the high performance of MI cable, the cable must be properly stored and the ends must remain sealed.

Damaged terminations or heat-shrinkable end caps that are damaged, missing, or removed will cause the magnesium oxide insulation (white powder) to absorb moisture, resulting in low IR readings. The cable must be "heated out" to remove the moisture and bring the IR back to an acceptable level. Drying out the MI cable to remove any moisture will normally be unnecessary providing the termination seal is completed within a few minutes of removing the sheath.

If moisture is found in the cable when checking IR, it may be removed using one of the following methods:

1. If excess cable is available, 6 to 12 in (15 to 30 cm) of cable may be removed from the end before sealing the cable.
2. Apply heat to the cable following the procedure below.

 **Note: Moisture will not normally penetrate more than 12 in (30 cm) into the cable.**

 **Note: Use heat resistant gloves and eye protection when heating the cable.**

If moisture is detected in the cable, use an oxyacetylene or mapp gas torch with a large flame and "heat out" the cable beginning 12 in (30 cm) back from the end. Gradually move the flame toward and past the cable end. Copper sheath cables should be heated to a bluish-gray color. Take care not to overheat any one area of the cable sheath as this could damage the cable.

Use a short sweeping motion of the torch and heat about 2 in (5 cm) of cable at a time, repeating 4 to 5 times.

Move the flame towards the cable end as shown. Do not sweep the flame in the opposite direction as this will drive the moisture back into the cable.

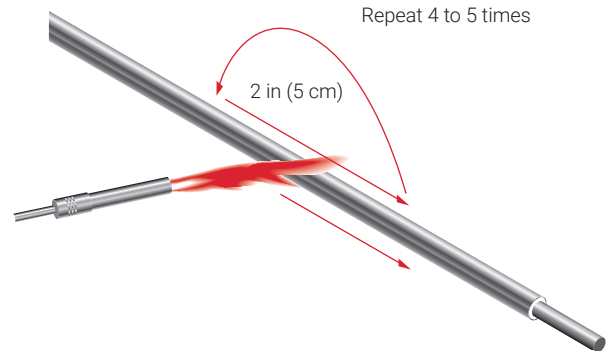

Gradually move the flame toward the end while maintaining the short sweeping motion of the torch. If you heat toward the cable end too quickly you may skip over the moisture and drive it further back into the cable.

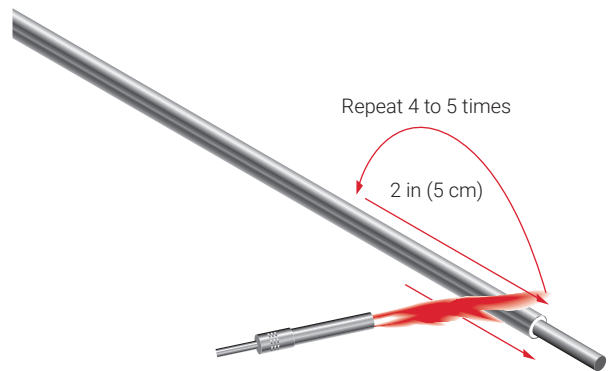

It may be necessary to repeat the above procedure several times to completely remove all moisture from the cable. Allow the cable to cool before repeating.

Notes:

North America
Tel +1.800.545.6258
Fax +1.800.527.5703
thermal.info@nvent.com

Europe, Middle East, Africa
Tel +32.16.213.511
Fax +32.16.213.604
thermal.info@nvent.com

Asia Pacific
Tel +86.21.2412.1688
Fax +86.21.5426.3167
cn.thermal.info@nvent.com

Latin America
Tel +1.713.868.4800
Fax +1.713.868.2333
thermal.info@nvent.com



nVent.com

©2018 nVent. All nVent marks and logos are owned or licensed by nVent Services GmbH or its affiliates. All other trademarks are the property of their respective owners. nVent reserves the right to change specifications without notice.

Pyrotenax-IM-H59479-JointandFireProtectionKit-EN-1811