

SERVICE ENTRANCE CABLE SYSTEM

This section provides an overview of general circuit design considerations and installation guidelines for a nVent PYROTENAX System 1850-SE Service Entrance (SE) mineral insulated cable system. This system is designed as an alternative to concrete encasement for service conductors. Where conditions make concrete encasement difficult or impractical, Authorities Having Jurisdiction (AHJs) have accepted this system as an alternative to concrete encasement. For additional information, contact your nVent representative or phone nVent at (800) 545-6258. Also, visit our web site at nVent.com.

CONTENTS

Introduction	1
Typical Locations	2
System 1850-SE	2
Ventilated Tray	3
Approvals and Certifications	3
Circuit Design Considerations	3
Cable Sizing	3
Voltage Drop	4
Equipment Bonding	4
Short Circuit Capability	5
Expansion and Vibration	5
Corrosion and MI Cable	5
Lightning Protection	5
Cable Termination	6
Factory and Field Splices	6
Typical System Installation	7
Installation Guidelines	7
Supporting System 1850-SE	8
Seismic Considerations	9
Cable Layout	9
Terminating System 1850-SE MI Cable	10
Connecting System 1850-SE MI Cable	10

INTRODUCTION

Increased power consumption due to the expansion of office space in existing buildings, as well as the conversion of buildings to commercial use, has resulted in greater demand for electrical power. Retrofitting service conductors can present particular difficulties as the electrical room is often located at a distance from the service entrance point. While this was a good location when the building was first constructed and service cables could easily be encased in concrete in the floor, it gives rise to significant difficulties after the fact, when encasement of the additional service conductors can be virtually impossible because of constricted space and congestion in service areas.

nVent PYROTENAX System 1850-SE allows up to 80% space savings over traditional rigid conduit and wire solutions. The decision to accept the system as a alternative to concrete encasement is the responsibility of the Authorities Having Jurisdiction (AHJs). If accepted, either on a case-by-case basis or carte blanche as has been the case in several major cities, the system provides an effective solution to a difficult problem.

Typical Locations

System 1850-SE is ideal for high-capacity feeders and low-profile wiring in the following locations:

- Older high-rise buildings
- Historic buildings
- Health care facilities

System 1850-SE

A PYROTENAX System 1850-SE installation consists of System 1850 2-hour fire-rated single conductor MI cable, with special terminations for service entrance applications, and enclosed ventilated cable tray. System 1850-SE should be supported by steel rod and channel (trapeze) systems in one of two configurations.

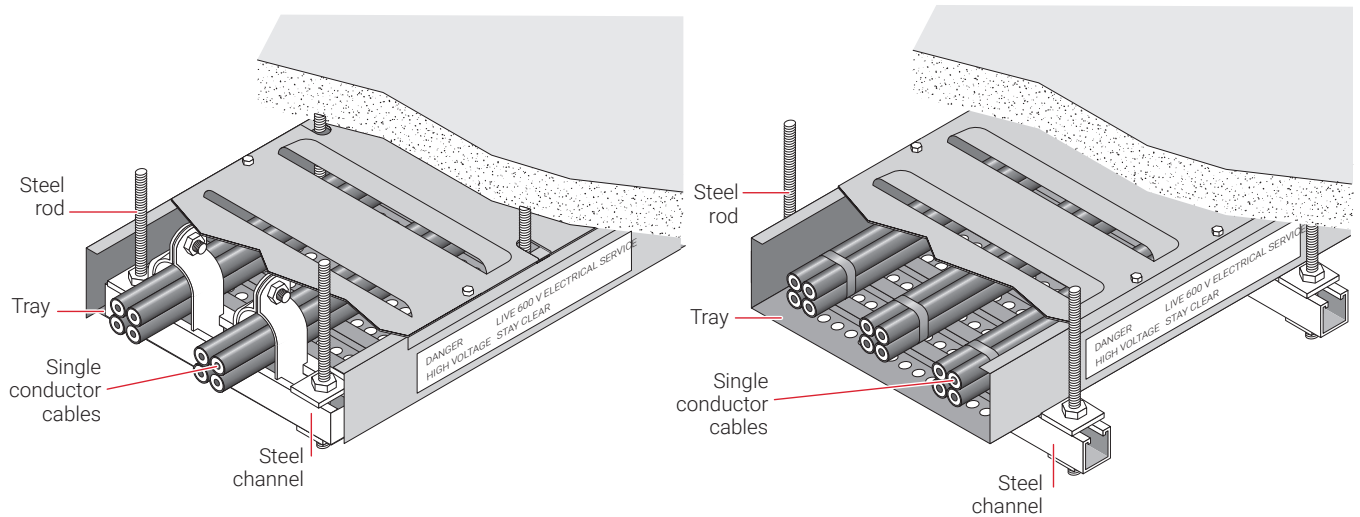

Fig. 1 System 1850-SE configurations

System 1850-SE MI cable is installed in an enclosed ventilated tray labeled along its length with warnings that this is a “live electrical service.”

SYSTEM 1850 2-HOUR FIRE-RATED MINERAL INSULATED CABLE

PYROTENAX System 1850 MI wiring cables are manufactured using only inorganic materials, copper and magnesium oxide. This construction is inherently tough, yet allows the cable to be bent and molded to fit into tight spaces. In addition, the totally inorganic construction of unjacketed System 1850 cables allows for an environmentally clean electrical cable that does not burn, produce smoke, or add fuel when exposed to fire conditions.

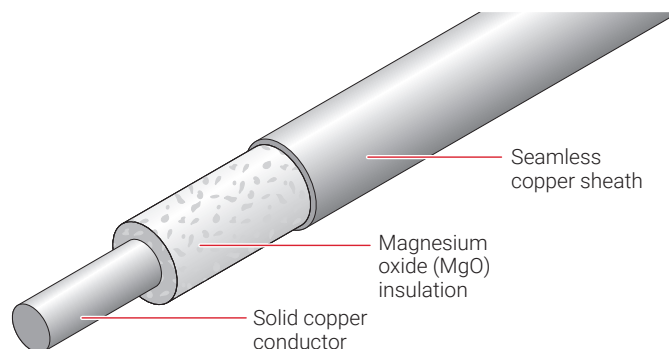

Fig. 2 System 1850 MI cable construction

For service entrance applications, both 350 kcmil and 500 kcmil single conductor cables are available. For specifications, see the product data sheet in the Technical Data section.

VENTILATED TRAY

A NEMA Class 12B Stainless steel ventilated tray complete with louvered cover, clamps, 90° and 45° bends, offsets, etc. is supplied.

The steel rod and channel used for the trapeze supports is not supplied.

Approvals and Certifications

All components of System 1850-SE are UL Listed and/or CSA Certified in North America.

CIRCUIT DESIGN CONSIDERATIONS

Service entrance systems should only be designed by professionals familiar with generally accepted design practices. The information provided below relates specifically to designs using PYROTENAX System 1850-SE and must be followed, along with all relevant local codes and standards, to ensure that the systems are designed properly. For additional information, contact your nVent representative or phone nVent at (800) 545-6258.

Cable Sizing

System 1850-SE MI cable size is based on circuit breaker size, which in turn is based on load calculations. After choosing the appropriate circuit breaker size, use the ampacity tables specified in the electrical code to determine the cable size. If the calculated voltage drop exceeds the specified limits, a larger cable size must be chosen.

The National Electrical Code (NEC) allows full “free air” ampacity for unjacketed single conductor MI cables configured according to Fig. 3 as long as a space of 2.15 cable diameters is maintained between bundles.

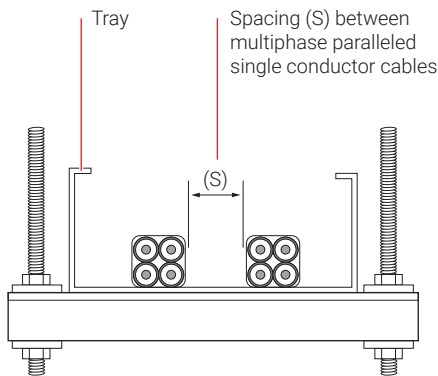

Fig. 3 Spacing of bundled conductors

Although unjacketed single conductor MI cable is unaffected by any temperature increase resulting under the installation conditions shown in Fig. 3, the termination may need to be “sized-up” to keep it within its temperature limits in accordance with electrical code requirements. Refer to Table 1, later in this section for more details.

Voltage Drop

Voltage drop calculations are based on calculated load, not circuit breaker rating.

For conventional cables, simple formulas are used to determine if the cable size listed in the ampacity tables meets the required voltage drop limits. While these formulas can be applied to System 1850-SE MI cable, voltage drop values specific to the characteristics of MI cable can be calculated using any of the following:

- An equation based on the run length, the conductor current, and the circuit voltage is provided in Appendix: PYROTENAX MI Voltage Drop Calculation (H57611)
- A quick voltage drop calculator is available on the nVent web site, nVent.com
- PyroSizer MI cable sizing software is available from the nVent web site, nVent.com, or through your nVent representative

Equipment Bonding

The copper sheath of System 1850 cables meets the North American code requirements for an equipment grounding conductor. The brass gland completes the grounding path from the cable sheath to the equipment. For single conductor cables, the ground path includes a nonferrous brass plate, as shown in Fig. 4.

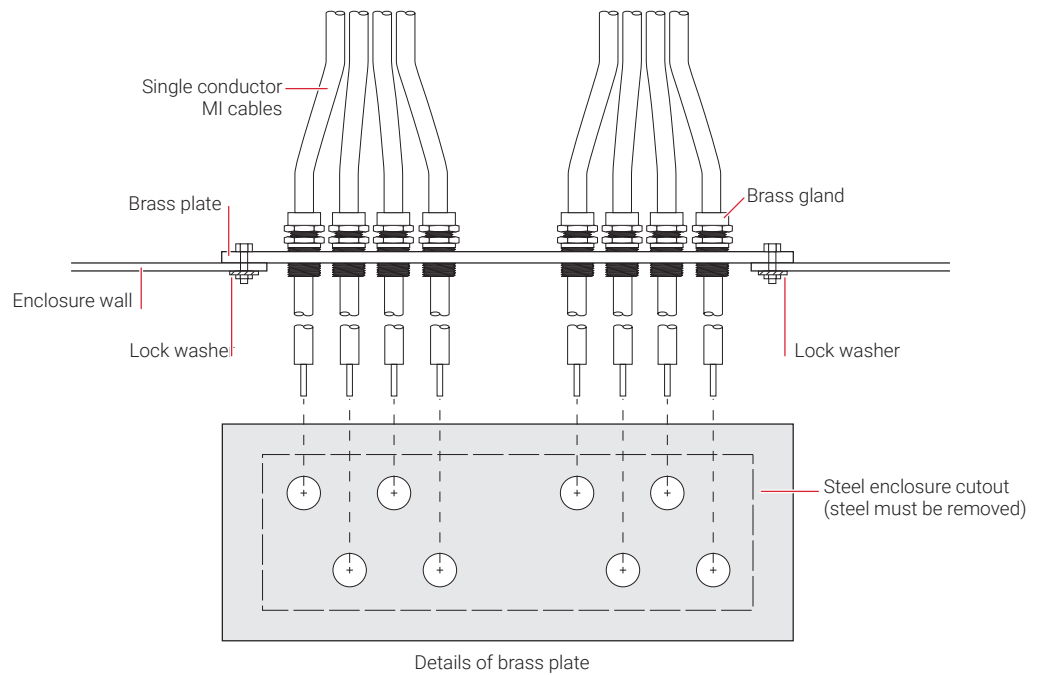

Fig. 4 Equipment bonding using brass plate

Short Circuit Capability

The following graphs give the maximum allowable short circuit currents for System 1850 cables. The first is based on the cable only. The cable will survive if the short circuit currents shown are not exceeded; however, the terminations could be damaged. The second graph provides the maximum short circuit current to avoid damage to terminations.

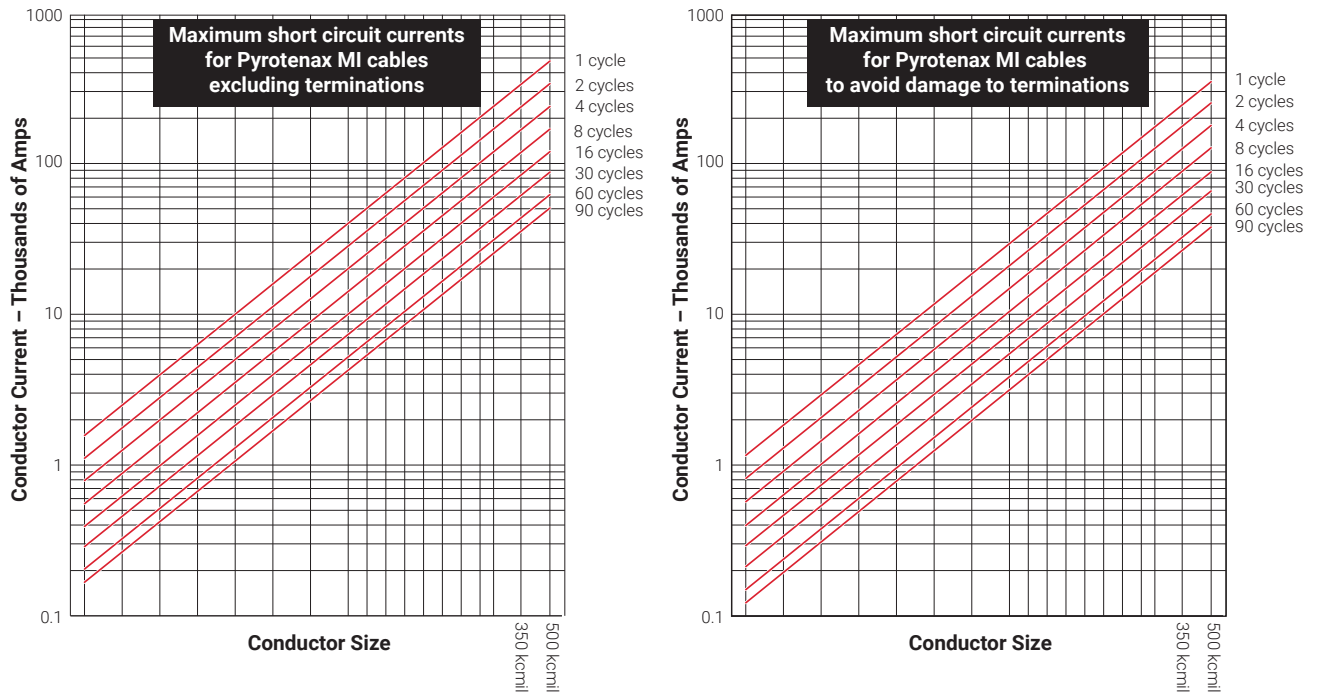

Fig. 5 Short circuit currents

To determine how System 1850-SE behaves when subjected to massive fault currents, tests were performed in which fault currents up to 40 kA at 600 V were fed into a deliberately created fault between the conductor and sheath and maintained for up to three seconds. The resulting arcing fault gave rise to substantial smoke and noise, but cardboard placed one foot under the tray was only pockmarked and did not ignite. For further details on the tests performed, contact your nVent representative or phone nVent at (800) 545-6258.

Expansion and Vibration

In applications subject to expansion or vibration, take precautions to prevent mechanical damage. See Appendix: PYROTENAX MI Cable Expansion and Vibration (H57613) for details.

Corrosion and MI Cable

In most applications, System 1850 cables can be used without any additional protection against corrosion. System 1850-SE is not suitable for use in corrosive conditions.

Lightning Protection

A lightning arrester kit, SE-Protect, must be installed in areas where lightning activity is exceptionally high, and may also be used in any location where there is a concern about lightning activity. For further information about SE-Protect, please contact nVent at (800) 545-6258.

Cable Termination

System 1850 cables are approved only when used with the appropriate PYROTENAX termination kits. The use of nonapproved components will compromise the reliability of the system and will invalidate approvals and warranties.

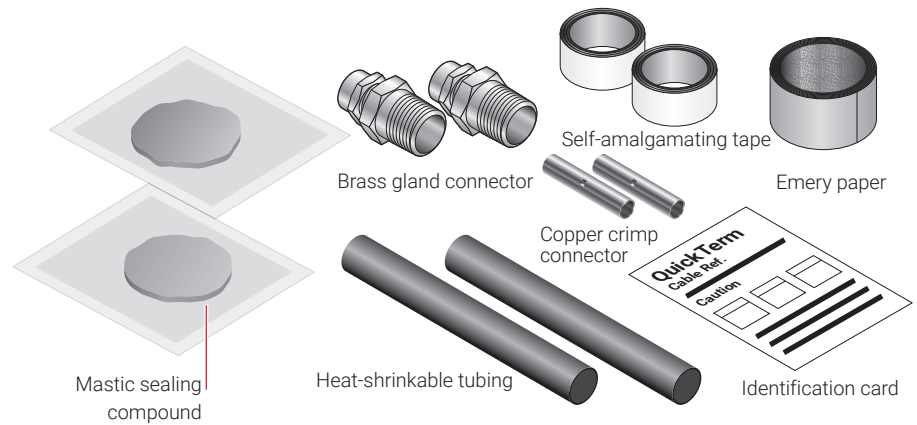

Fig. 6 SE-QuickTerm termination kit for System 1850-SE

The System 1850-SE cable uses a special termination kit to splice the solid MI conductor to a flexible tail (flexible tail not supplied).

The termination procedure for System 1850-SE cables must be reviewed prior to installation and terminations must be installed under the supervision of a nVent Field Services Engineer. The Service Entrance QuickTerm kit uses mastic sealing compound as well as self-amalgamating tape. The mastic sealing compound must be carefully kneaded in and around the open end of the cable, between the conductor and sheath, before applying the self-amalgamating tape.

TABLE 1 SELECTION TABLE FOR SE-QUICKTERM TERMINATION KIT AND FLEXIBLE TAIL SIZE

MI cable size	Circuit ampacity	If landing on:	Termination method	Flexible tail size
350 kcmil	310 A maximum	Circuit breaker	Size-for-size	350 kcmil
	475 A maximum	Circuit breaker	Sized-up	750 kcmil
	505 A maximum	Bus bar	Sized-up	750 kcmil
500 kcmil	380 A maximum	Circuit breaker	Size-for-size	500 kcmil
	475 A maximum	Circuit breaker	Sized-up	750 kcmil
	620 A maximum	Bus bar	Sized-up	750 kcmil

Factory and Field Splices

Splices must not be used for service entrance applications.

Typical System Installation

A typical System 1850-SE service entrance installation is shown in Fig. 7.

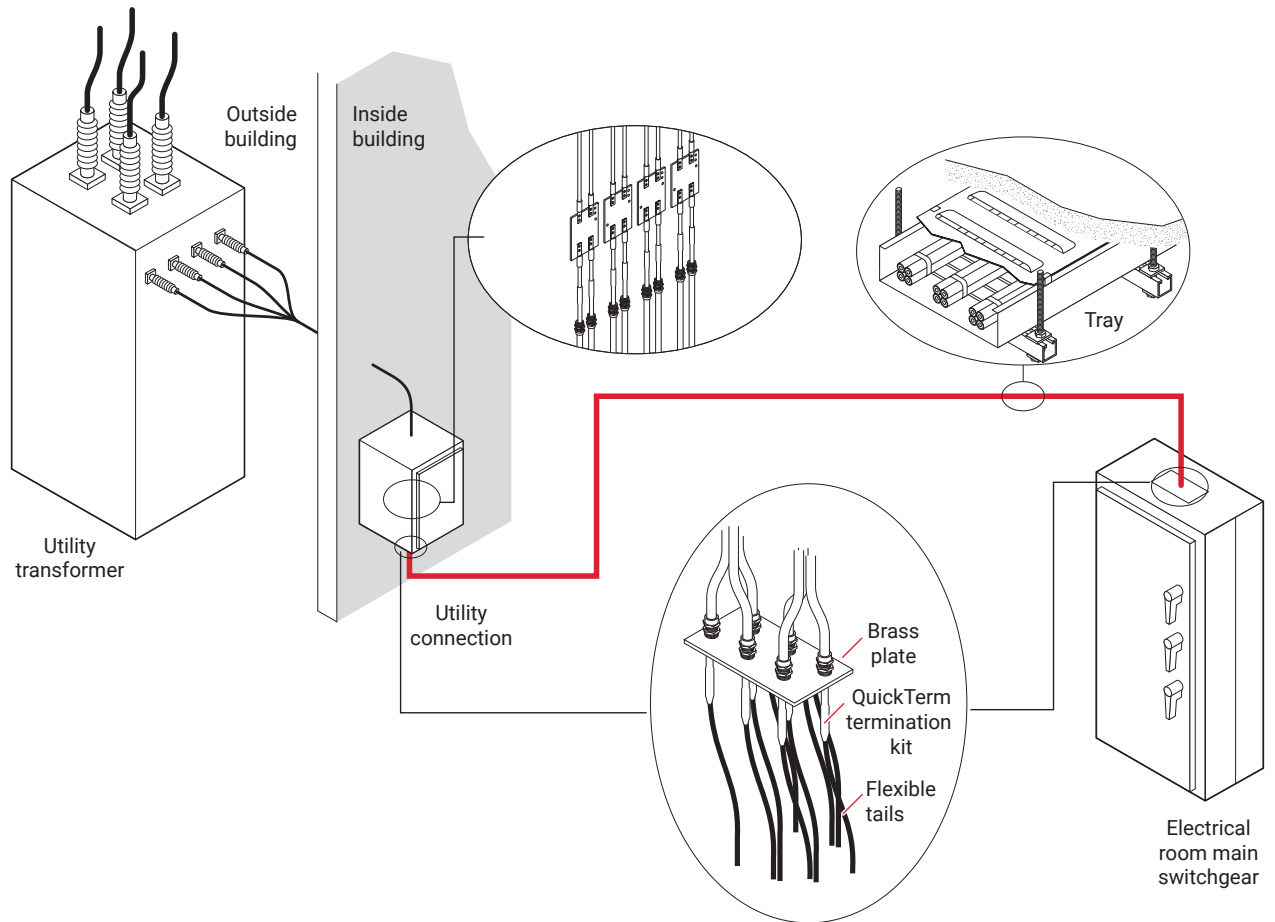

Fig. 7 Typical System 1850-SE system

INSTALLATION GUIDELINES

These installation guidelines apply to System 1850-SE only. When installing a system, refer to the System 1850-SE data sheet, and installation instructions shipped with the product, and available on the nVent web site at nVent.com. A nVent Field Service Engineer must be on site before the installation and for commissioning. Refer to national and local electrical codes for additional details. For further information, contact your nVent representative or phone nVent at (800) 545-6258.



Important: System 1850-SE terminations are different from other MI cable terminations and must be installed under the supervision of a nVent Field Service Engineer.

Supporting System 1850-SE

It is important that all support components are made of appropriate materials, such as steel, stainless steel, and concrete. Low melting point or combustible materials such as aluminum, brass, plastic, lead, wood, etc. are not acceptable. For additional information on supporting System 1850-SE, contact your nVent representative or phone nVent at (800) 545-6258.

System 1850-SE cables are installed in ventilated cable tray supported by steel rod and channel (trapeze) systems suspended from the ceiling. nVent loading requirements call for limits to the load on the steel rods. In addition, UL listing requirements stipulate support spacing at certain intervals. The combination can lead to closer spacing between supports than normal.

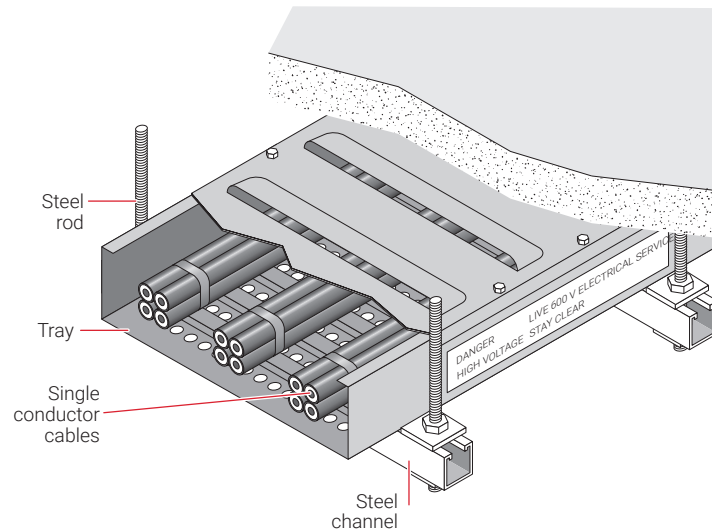

Fig. 8 Supporting System 1850-SE

System 1850-SE service entrance cable must be supported at intervals dependent on the cable tray loading and the configuration (number of trays, size of trapeze rods). Contact nVent for the calculated distance between supports, based on the specific installation configuration.

TABLE 2 CONFIGURATION FOR 4-WIRE SYSTEM, 500 KCMIL MI

No. of sets	4' spacing		6' spacing	
	Rod diameter	No. of channels	Rod diameter	No. of channels
1–5	1/2"	Single	1/2"	Single
6	1/2"	Single	5/8"	Double
7–8	5/8"	Double	3/4"	Double
9	5/8"	Double	†	†
10	†	†	†	†
11–14	†	†	†	†

1. Maximum width of 1-1/2 in (38 mm) channel: 36 in (915 mm)

† Either support spacing must be reduced or cable tray may be double stacked to reduce load on channel. Contact nVent for assistance.

TABLE 3 CONFIGURATION FOR 4-WIRE SYSTEM, 350 KCMIL MI

No. of sets	4' spacing		6' spacing	
	Rod diameter	No. of channels	Rod diameter	No. of channels
1–5	1/2"	Single	1/2"	Single
6–8	1/2"	Single	5/8"	Double
9	1/2"	Double	5/8"	Double
10	5/8"	Double	3/4"	Double
11–14	†	†	†	†

1. Maximum width of 1-1/2 in (38 mm) channel: 36 in (915 mm)

† Either support spacing must be reduced or cable tray may be double stacked to reduce load on channel. Contact nVent for assistance.

Seismic Considerations

In areas where there is a risk of seismic activity, precautions must be taken where the cable crosses expansion joints and at termination points. For more information, see Appendix: PYROTENAX MI Cable Expansion and Vibration (H57613).

Cable Layout

Single conductor System 1850-SE cables should be bundled in groups containing one conductor from each phase to minimize the resulting magnetic field in each grouping. The grouped single conductor cables are then fastened tightly together, ensuring that the gland connector at each end of the cable run is connected to the metal enclosure through a brass plate. Typical single conductor cable configurations are shown in Fig. 9. The neutral conductor may be located within or outside the cable group.

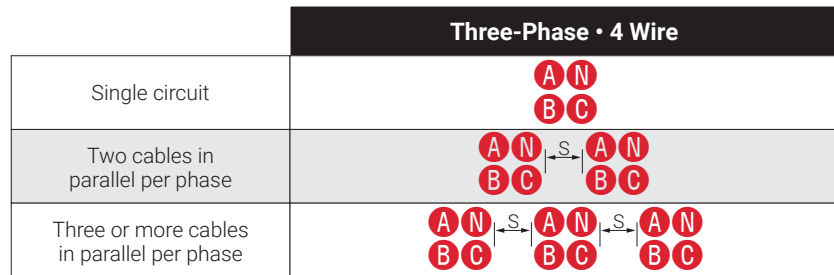

Note: The spacing "S" between bundles should be a minimum of 2.15 cable diameters in the U.S. (NEC). Neutral may be located as shown, or outside groups in the most convenient location.

Fig. 9 Recommended installation configurations

Electrical codes generally limit paralleling cable configurations to cable sizes 1/0 AWG and larger. The codes address the balancing of resistance by stipulating:

- All conductors must be the same length
- All conductors must be the same size and the same material
- All conductors must have the same type of insulation
- All conductors must be terminated in the same manner

A current measurement should be taken immediately after the cables begin to carry load. Load imbalances between conductors of up to 10% are tolerable and expected. Deviations above 10% should be investigated and corrected.

When installing single conductor cables through a ferrous enclosure, precautions must be taken to prevent induction heating in the steel. This is accomplished by removing a section of the enclosure and installing a nonferrous brass plate. Brass plates with pretapped holes are available for the gland connectors.

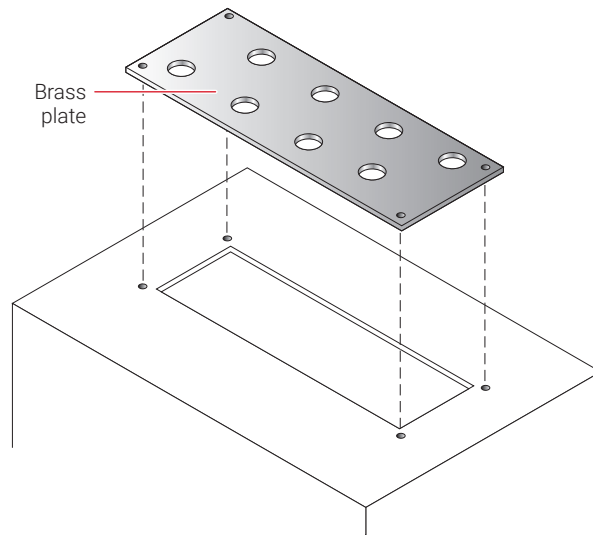

Fig. 10 Enclosure with cutout and brass plate

Terminating System 1850-SE MI Cable

Important: System 1850-SE terminations are different from other MI cable terminations and must be installed under the supervision of a nVent Field Service Engineer.

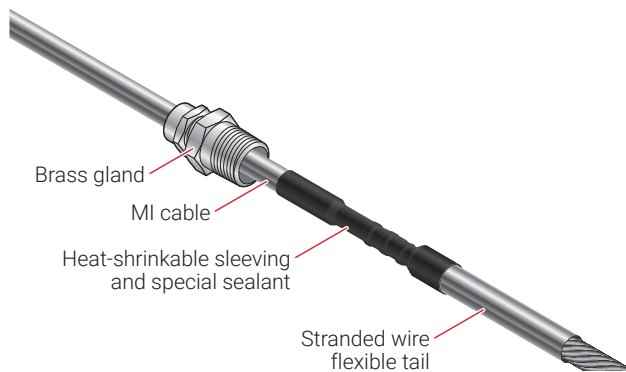

Fig. 11 System 1850-SE termination

Connecting System 1850-SE MI Cable

The termination gland is a 1-1/4" NPT brass gland that simultaneously seals the enclosure and grips the cable through a brass compression sleeve when tightened to the recommended torque (25 ft-lbs). This connection, when installed according to the installation instructions, provides the following benefits:

- Code-compliant bonding path from the cable sheath
- Hydrostatic withstand pressure up to 500 lbs/in² (35 kg/cm²)

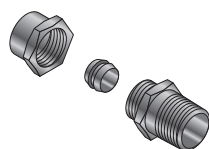

Fig. 12 Brass gland

Note: The terminations are not required to be fire-rated, since the emergency equipment they serve is in a fire-rated room.

North America

Tel +1.800.545.6258
Fax +1.800.527.5703
thermal.info@nvent.com

Europe, Middle East, Africa

Tel +32.16.213.511
Fax +32.16.213.604
thermal.info@nvent.com

Asia Pacific

Tel +86.21.2412.1688
Fax +86.21.5426.3167
cn.thermal.info@nvent.com

Latin America

Tel +1.713.868.4800
Fax +1.713.868.2333
thermal.info@nvent.com



nVent.com

Our powerful portfolio of brands:

CADDY ERICO HOFFMAN RAYCHEM SCHROFF TRACER